

FRAME SECTION

(2) BOLT SOCKET (ALLEN HEAD)
5/8"-11 X 1 1/2" STAINLESS STEEL
(PART# 00981177)

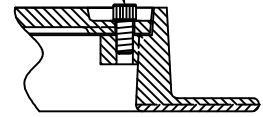

BOLTING DETAIL

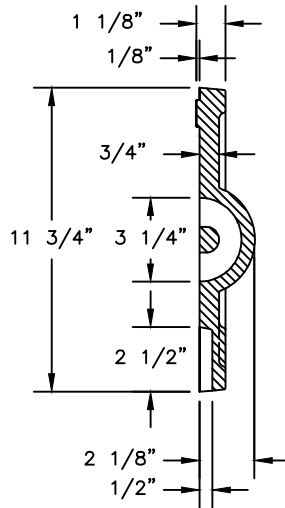

COVER SECTION

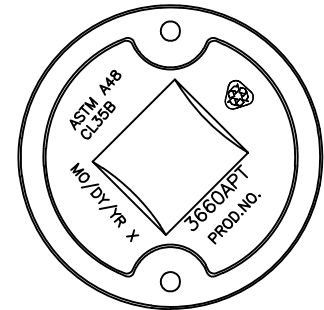

COVER BACK

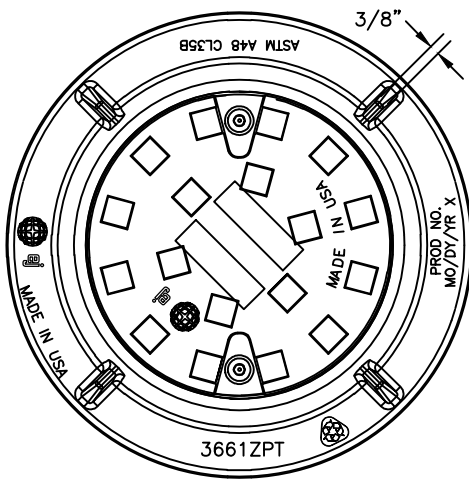

COVER AND FRAME PLAN

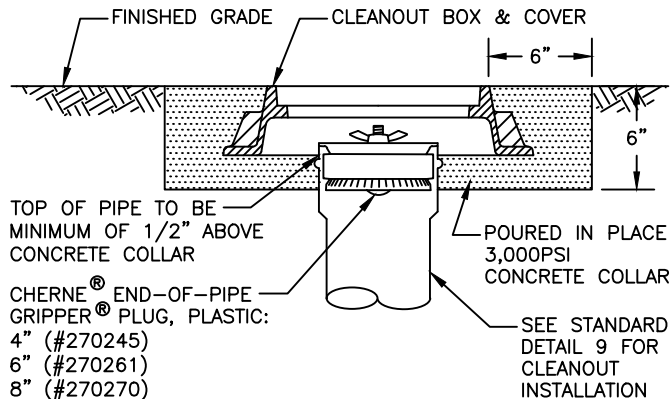

INSTALLATION PROFILE

NOTES:

1. SURFACE CLEANOUTS ARE REQUIRED AT THE R.O.W., THE BUILDING CONNECTION IN HARDSCAPE (SUCH AS SIDEWALKS, DRIVEWAYS, AND PATIOS), AND EVERY 100 FEET. THE SIDE SEWER CONNECTION AT THE MAIN LINE STUB SHALL BE A TWO-WAY CLEANOUT TEST TEE. SEE STANDARD DETAILS 7 & 8a.
2. CLEANOUT BOXES AND COVERS LOCATED AT PROPERTY LINE AND IN HARDSCAPES SHALL BE EAST JORDAN IRONWORKS GRAY IRON ASSEMBLY, PART #00366107, HEAVY DUTY RATED WITH STAINLESS STEEL ALLEN HEAD SOCKET BOLTS.
3. CLEANOUT BOXES AND COVERS LOCATED IN LANDSCAPE AREA'S WITHIN THE PROPERTY MAY BE A MINIMUM 6" ROUND OR 6" SQUARE LANDSCAPE/IRRIGATION BOX EQUIVALENT TO A CARSON TRUSST 708, NDS 107BC, OR NDS D1000-SG.
4. WOOD SHIMS ARE NOT ALLOWED. PLASTIC OR CONCRETE SHIMS ARE TO BE USED FOR PLACING CLEANOUT BOX WHILE CONCRETE COLLAR IS POURED.

SURFACE CLEANOUT BOX

NOT TO SCALE

DETAIL APPROVALS
EDITOR TMC
MANAGER EM

NORTHSHORE UTILITY DISTRICT
2024 STANDARD SEWER DETAILS



LAST UPDATED
MARCH 2024