

EXISTING CONCRETE BASE PLAN

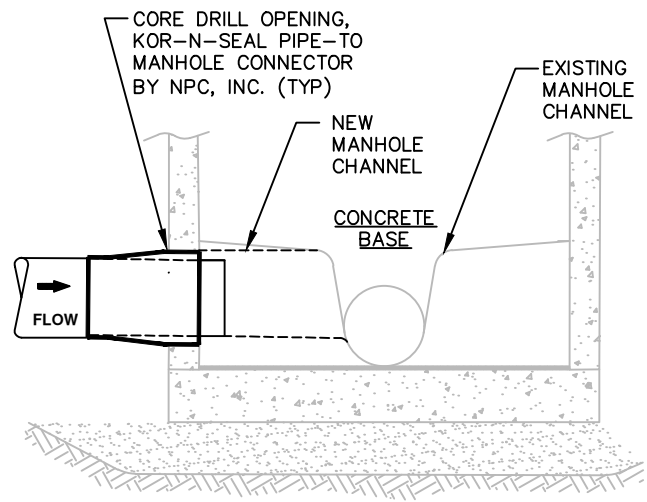

SECTION A-A

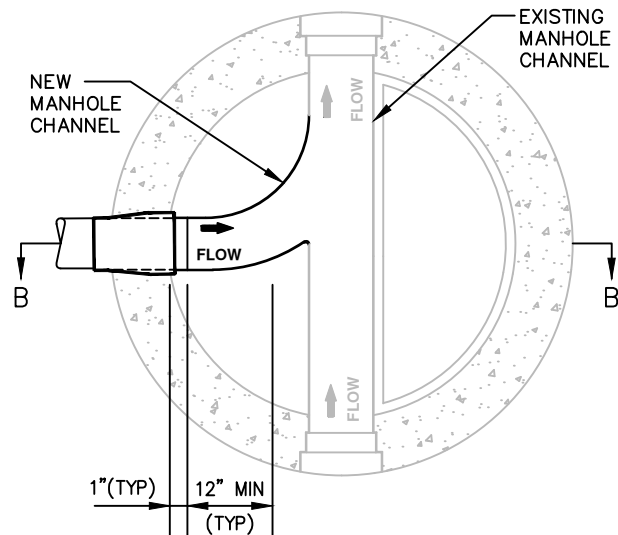

EXISTING F.R.P./P.P. LINER PLAN

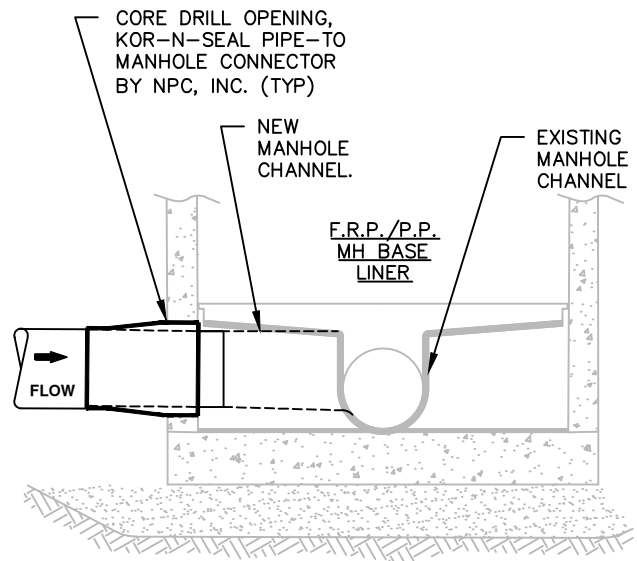

SECTION B-B

NOTES:

1. IF P.P. BASE LINER IS UTILIZED, A MINIMUM SLOPE OF 0.06' IS ACCEPTABLE ACROSS THE INVERT CHANNEL. THE F.R.P. BASE LINER SHALL REQUIRE THE DISTRICT STANDARD MINIMUM SLOPE OF 0.1' ACROSS THE INVERT CHANNEL.
2. THE NEW CHANNEL SHALL HAVE NO SHARP EDGES AND SHALL DIRECT FLOW TOWARDS EXISTING FLOW DIRECTION. NO 90° BENDS IN THE CHANNELING.
3. CONCRETE BASES SHALL BE RE-CHANNELED USING 3,000 PSI STRUCTURAL CONCRETE.
4. FIBER REINFORCED PLASTIC (F.R.P.) AND POLYPROPYLENE (P.P.) BASE LINERS SHALL BE RE-GLASSED PER MANUFACTURER'S SPECIFICATIONS. PLEASE CONTACT NORTHSORE UTILITY DISTRICT FOR REPAIR REQUIREMENTS.
5. SEE NUD SEWER DETAIL #1 FOR PRECAST CONCRETE MANHOLE, TOP SECTION, LADDER, AND STEPS.
6. CROWN OF NEW PIPE CONNECTION SHALL MATCH EXISTING CHANNEL'S CROWN OR AS APPROVED BY DISTRICT.

NEW CONNECTION TO EXISTING MANHOLE

NOT TO SCALE

DETAIL APPROVALS

ENGINEER *TMC*

MANAGER *SJD*

NORTHSORE UTILITY DISTRICT

2023 STANDARD SEWER DETAILS

15

LAST UPDATED
JANUARY 2023