

PLAN VIEW
NOT TO SCALE

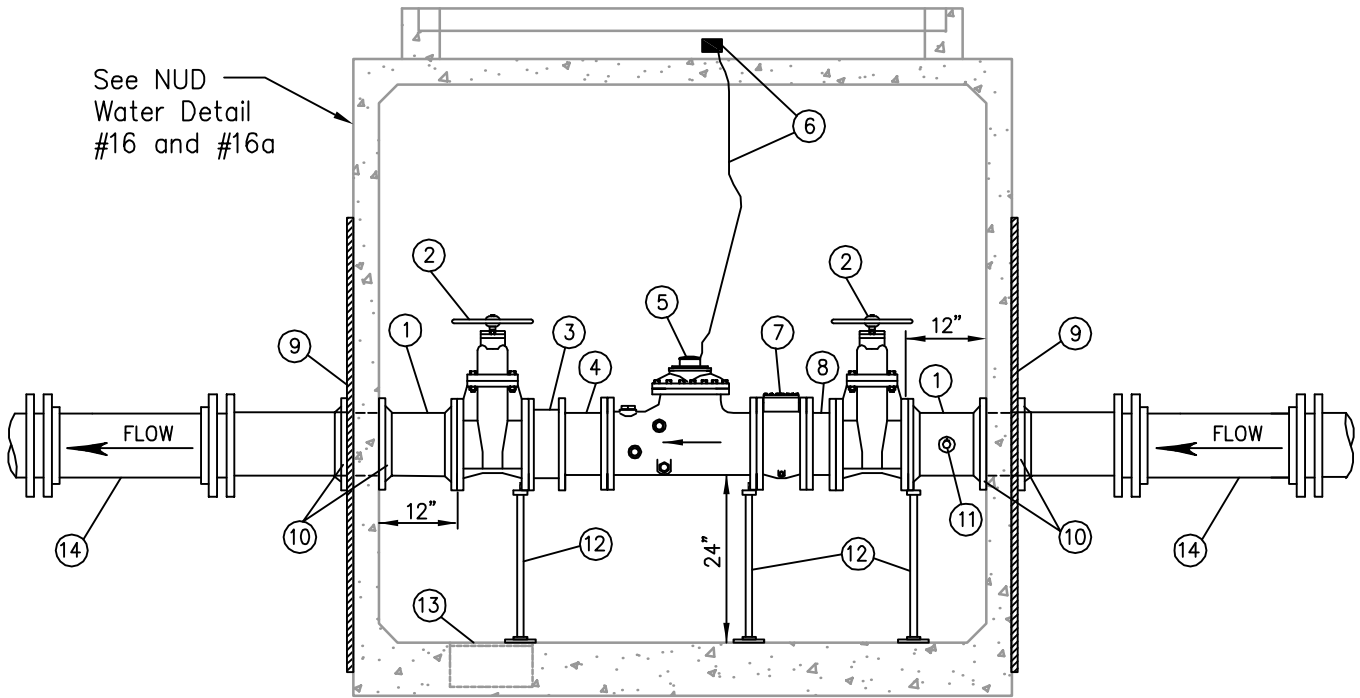

SECTION A-A
NOT TO SCALE

4" & 6" WATER SERVICE

NOT TO SCALE

Detail Approvals
 Engineer GSM
 Manager DPK

NORTHSHORE UTILITY DISTRICT STANDARD WATER DETAILS

7

MATERIAL LIST: ALL PIPING & APPURTENANCES TO MATCH METER SIZE

ITEM	QTY.	DESCRIPTION
①	2	D.I. ADAPTER, FL x PE, 5'± LONG.
②	2	RESILIENT SEAT GATE VALVE, NRS, FL, O-RING PACKING WITH HANDWHEEL. VALVE TO BE AMERICAN, WATEROUS, MUELLER OR CLOW MEETING AWWA C-515.
③	1	FLANGED COUPLING ADAPTER TO BE FORD FLANGED COUPLING ADAPTER, STYLE FFCA W/STAINLESS STEEL ANCHOR STUDS, OR EQUAL.
④	1	D.I. ADAPTER, FL x PE, LENGTH TO FIT.
⑤	1	FLANGED SINGLE REGISTER HIGH PERFORMANCE COMPOUND METER, TO BE PROVIDED BY DISTRICT AND INSTALLED BY CONTRACTOR.
⑥	1	METER TRANCEIVER UNIT (MXU) AND MOUNTING BRACKET, TO BE PROVIDED BY DISTRICT AND INSTALLED BY CONTRACTOR ON HATCH RISER.
⑦	1	FLANGED STRAINER, TO BE PROVIDED BY DISTRICT AND INSTALLED BY CONTRACTOR.
⑧	1	5" D.I. SPOOL, FL X FL
⑨	4	2" X 2" X 1/4" MIN. WALL THICKNESS SQUARE STEEL TUBING, 6' MIN. LENGTH. BOLT TO VAULT WALL IN FOUR PLACES WITH STAINLESS STEEL ANCHOR BOLTS.
⑩	4	UNI-FLANGE ADAPTER.
⑪	1	SADDLE WITH STAINLESS STEEL STRAP, 1" IP TAP AND 1" MIP LOCKABLE BALL VALVE WITH CAP.
⑫	3	AJUSTABLE PIPING SUPPORT, STANDON MODEL #S89, OR EQUAL.
⑬	1	SUMP PUMP OR GRAVITY DRAIN AS REQUIRED BY SITE CONDITIONS, TO BE DETERMINED BY THE DEVELOPER AND CONTRACTOR AND REVIEWED AND APPROVED BY THE DISTRICT. FOR GRAVITY: SUMP DRAIN, ZURN Z-551, THREADED, WITH ZURN Z-1099 BACKWATER VALVE, THREADED x NO-HUB, WITH 4" D.I. PIPE TO 12" MIN. BEYOND VAULT WALL AND 4" D.I., MIN. 1% SLOPE TO DAYLIGHT OR C.B. FOR SUMP PUMP: 16" DIAM. x 6" DEEP SUMP WITH ZOELLER MODEL 57 SUMP PUMP. PROVIDE ELECTRICAL POWER PER ALL APPLICABLE CODES. CONSTRUCT 1-1/4", SCH. 80 PVC DISCHARGE PIPING, WITH LOCATE WIRE TO NEAREST CATCH BASIN OR APPROVED LOCATION.
⑭	2	D.I. TEE, FL x RJ.
⑮	2	RESILIENT SEAT GATE VALVE, NRS, FL x RJ. VALVE TO BE AMERICAN, WATEROUS, MUELLER, M&H, OR CLOW MEETING AWWA C-509. VALVE BOX TO BE PER DISTRICT STANDARD WATER DETAIL #9.
⑯	2	D.I. SPOOLS, 1'± LONG.
⑰	2	90° D.I. BENDS, RJ.
⑱	1	2" BLOW-OFF ASSEMBLY, PER DISTRICT STANDARD WATER DETAIL #10.
⑲	1	D.I. SPOOL, 3'± LONG.

NOTES:

1. PROVIDE SHOP DRAWINGS AND SUBMITTALS FOR ALL MATERIALS TO THE DISTRICT FOR REVIEW AND APPROVAL PRIOR TO CONSTRUCTION.
2. VAULT SHALL BE UTILITY VAULT 687-LA (8'L x 6'W x 7'D; INSIDE DIMENSION). SEE DISTRICT STANDARD DETAIL #'S 16 AND 16a FOR VAULT DETAIL.
3. ALL PIPE AND CONDUIT PENETRATIONS SHALL BE CORE-DRILLED ON-SITE AND SHALL BE SEALED WATERTIGHT. PROVIDE "LINK-SEAL" FITTINGS AT ALL PENETRATIONS.
4. ALL PIPING AND APPURTENANCES OUTSIDE THE VAULT SHALL BE RESTRAINED JOINT. IN ADDITION TO THE RESTRAINED JOINTS, THRUST BLOCKING AT ALL TEES AND BENDS PER DISTRICT STANDARD WATER DETAIL #'S 1 AND 2 SHALL BE REQUIRED.
5. THE CONTRACTOR IS RESPONSIBLE FOR ELECTRICAL PERMITS AND APPROVALS FOR SUMP PUMP INSTALLATIONS.
6. IF REQUIRED FOR PREMISE ISOLATION, AN APPROVED BACKFLOW ASSEMBLY SHALL BE INSTALLED IMMEDIATELY BEHIND THE WATER METER PER DISTRICT STANDARD DETAIL #14.

4" & 6" WATER SERVICE

NOT TO SCALE

Detail Approvals
 Engineer GSM
 Manager DPK

**NORTHSHORE UTILITY DISTRICT
 STANDARD WATER DETAILS**

7a