

FIRE HYDRANT LOCATION IN CUT OR FILL

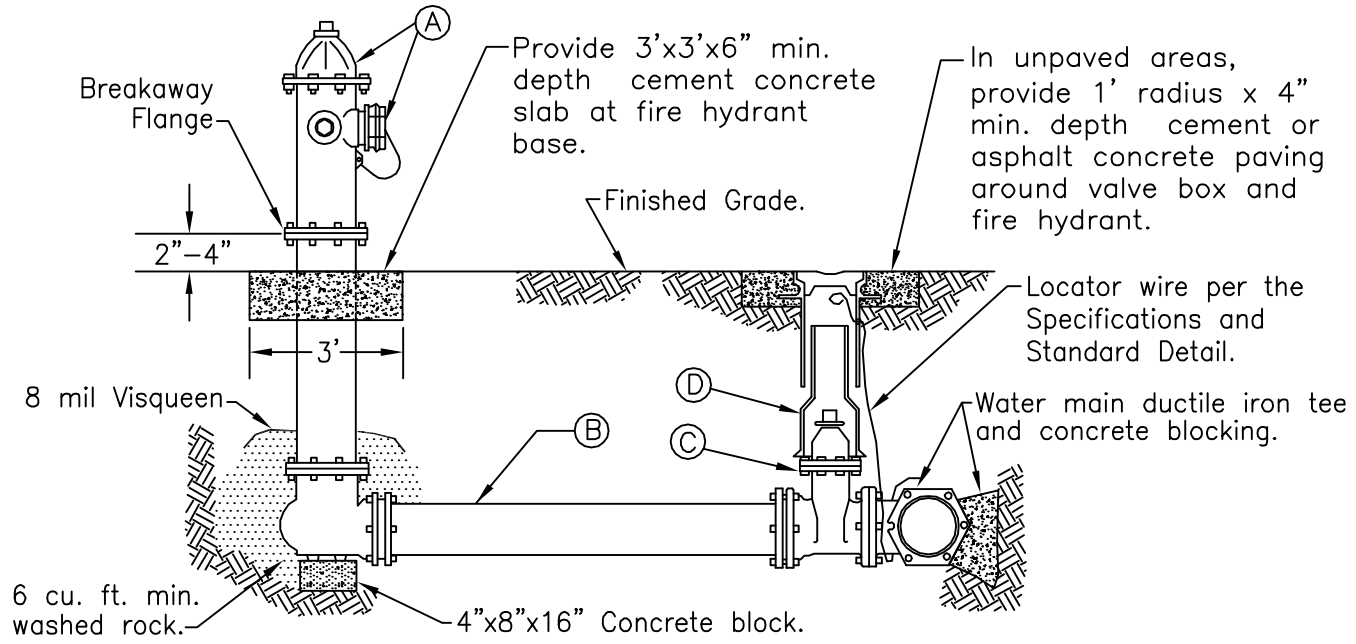

MATERIALS LIST

- | ITEM | DESCRIPTION |
|------|---|
| (A) | Hydrant: Shall be Mueller Super Centurion, American Darling B-62-B, Clow Medallion, M&H 929 or AVK Nostalgic in conformance with AWWA Standard Specification C-502. Provide Storz adapters as follows: 4" for Bothell and King Co. F.D. #16, 5" for Kirkland and none required for City of Woodinville. Hydrant shall be prime coated with Steelcote SR53 heavy duty brush type enamel. Top coat shall be two brush coats of Sherwin/Williams White Industrial Enamel #B54W101. |
| (B) | 6" Cl. 52 D.I. pipe, 3' min. and 50' max. with restrained joints. |
| (C) | 6" R.W. Gate valve, F.L.xR.J.: Shall be per the Specifications. |
| (D) | Two-piece valve box per the Specifications and Standard Detail. |

- Notes:**
- Hydrant shall be oriented per Fire Marshall and have 3' min. clearance around centerline.
 - Gate valve operating nut shall be 2' minimum and 4'-6" maximum from finished grade.
 - Bollards required only on private property.

FIRE HYDRANT ASSEMBLY

NOT TO SCALE

Detail Approvals	
Engineer	GSM
Manager	DPK

**NORTHSHORE UTILITY DISTRICT
STANDARD WATER DETAILS**