

PLAN VIEW

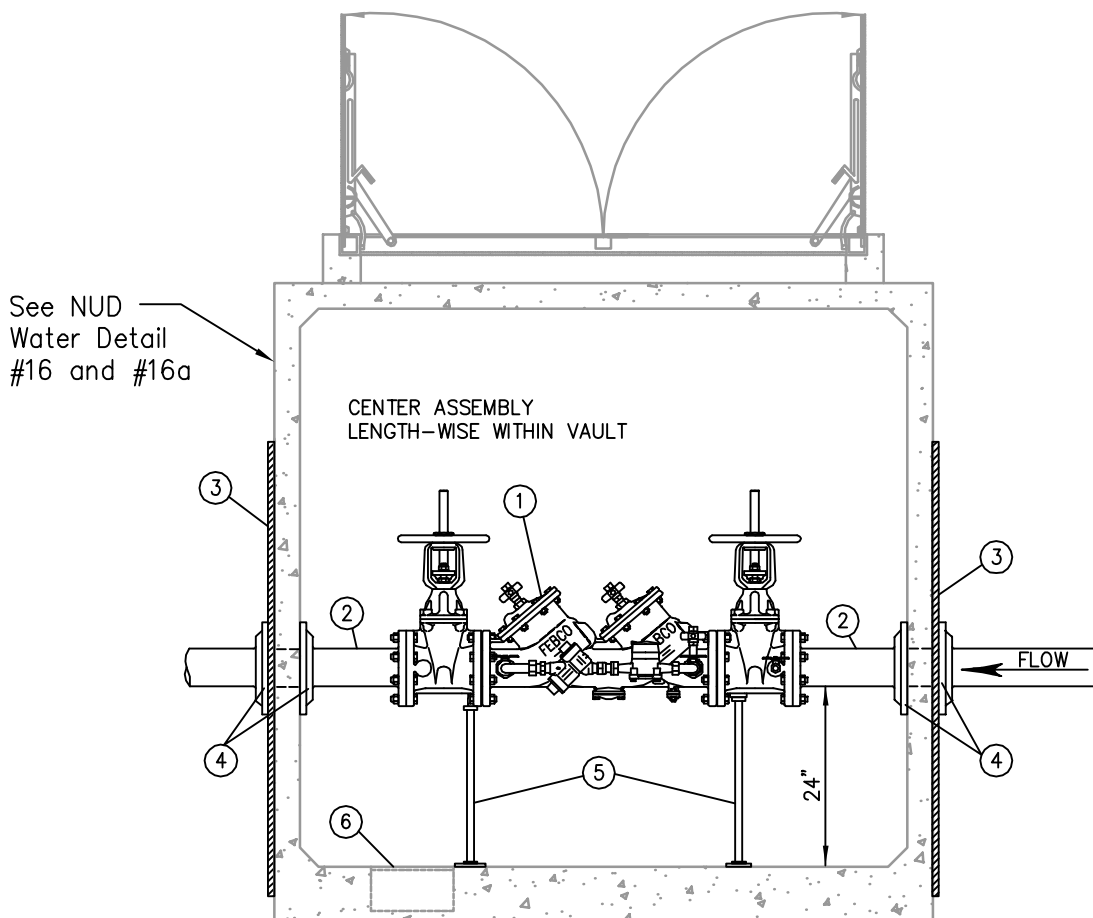

SECTION A-A

2 $\frac{1}{2}$ " - 8" DOUBLE CHECK DETECTOR ASSEMBLY

NOT TO SCALE

Detail Approvals
 Engineer GSM
 Manager DPK

**NORTHSHORE UTILITY DISTRICT
 STANDARD WATER DETAILS**

15

August 2011
 W-15(2.5-8_DCDA).dwg

MATERIAL LIST: ALL PIPING & APPURTENANCES TO MATCH DCDA SIZE

ITEM	QTY.	DESCRIPTION
①	1	DOUBLE CHECK DETECTOR ASSEMBLY SHALL BE FEBCO MODEL 856, WILKINS MODEL 350 DA, WATTS SERIES 757 DCDA, OR DISTRICT APPROVED EQUAL MEETING THE AWWA STANDARD C-510 AND BE WASHINGTON STATE APPROVED. TEST COCKS SHALL BE CAPPED WITH PLASTIC CAPS. BYPASS METER TO BE BADGER, M35 SHORT.
②	2	D.I. ADAPTER, FL x PE, 5'± LONG.
③	4	2" X 2" X 1/4" MIN. WALL THICKNESS SQUARE STEEL TUBING, 6' MIN. LENGTH. BOLT TO VAULT WALL IN FOUR PLACES WITH STAINLESS STEEL ANCHOR BOLTS.
④	4	UNI-FLANGE ADAPTER.
⑤	2	AJUSTABLE PIPING SUPPORT, STANDON MODEL #S89, OR EQUAL.
⑥	1	SUMP PUMP OR GRAVITY DRAIN AS REQUIRED BY SITE CONDITIONS, TO BE DETERMINED BY THE DEVELOPER AND CONTRACTOR AND REVIEWED AND APPROVED BY THE DISTRICT. FOR GRAVITY: SUMP DRAIN, ZURN Z-551, THREADED, WITH ZURN Z-1099 BACKWATER VALVE, THREADED x NO-HUB, WITH 4" D.I. PIPE TO 12" MIN. BEYOND VAULT WALL AND 4" D.I., MIN. 1% SLOPE TO DAYLIGHT OR C.B. FOR SUMP PUMP: 16" DIAM. x 6" DEEP SUMP WITH ZOELLER MODEL 57 SUMP PUMP. PROVIDE ELECTRICAL POWER PER ALL APPLICABLE CODES. CONSTRUCT 1-1/4", SCH. 80 PVC DISCHARGE PIPING, WITH LOCATE WIRE TO NEAREST CATCH BASIN OR APPROVED LOCATION.

NOTES:

1. PROVIDE SHOP DRAWINGS AND SUBMITTALS FOR ALL MATERIALS TO THE DISTRICT FOR REVIEW AND APPROVAL PRIOR TO CONSTRUCTION.
2. DOUBLE CHECK DETECTOR ASSEMBLY AND ALL PIPING SHALL BE SIZED BY A LICENSED FIRE SPRINKLER ENGINEER/CONTRACTOR.
3. VAULT SHALL BE UTILITY VAULT 687-LA (8'L x 6'W x 7'D; INSIDE DIMENSION). SEE DISTRICT STANDARD DETAIL #S 16 AND 16a FOR VAULT DETAIL.
4. ALL PIPE AND CONDUIT PENETRATIONS SHALL BE CORE-DRILLED ON-SITE AND SHALL BE SEALED WATERTIGHT. PROVIDE "LINK-SEAL" FITTINGS AT ALL PENETRATIONS.
5. ALL PIPING AND APPURTENANCES OUTSIDE THE VAULT SHALL BE RESTRAINED JOINT. IN ADDITION TO THE RESTRAINED JOINTS, THRUST BLOCKING AT ALL TEES AND BENDS PER DISTRICT STANDARD WATER DETAIL #S 1 AND 2 SHALL BE REQUIRED.
6. THE CONTRACTOR IS RESPONSIBLE FOR ELECTRICAL PERMITS AND APPROVALS FOR SUMP PUMP INSTALLATIONS.
7. THE DCDA SHALL BE INSTALLED OUTSIDE OF THE BUILDING IN A VAULT PER DISTRICT STANDARD DETAIL #S 16 AND 16A. INSTALLATION OF THE DCDA INTERNAL TO THE BUILDING WILL NOT BE ALLOWED UNLESS APPROVED BY THE DISTRICT (SITE SPECIFIC CONDITIONS OR CONSTRAINTS WILL BE CONSIDERED FOR ALTERNATE LOCATION OF THE DCDA).
8. NUD'S OWNERSHIP WILL BE TO THE UPSTREAM EDGE OF THE VAULT, OR IF THE DCDA IS ALLOWED WITHIN A STRUCTURE, UP TO THE FACE OF THE BUILDING.

2 1/2" - 8" DOUBLE CHECK DETECTOR ASSEMBLY

NOT TO SCALE

Detail Approvals
 Engineer GSM
 Manager DPK

**NORTHSHORE UTILITY DISTRICT
 STANDARD WATER DETAILS**

15a

August 2011
 W-15(2.5-8_DCDA).dwg