

SECTION

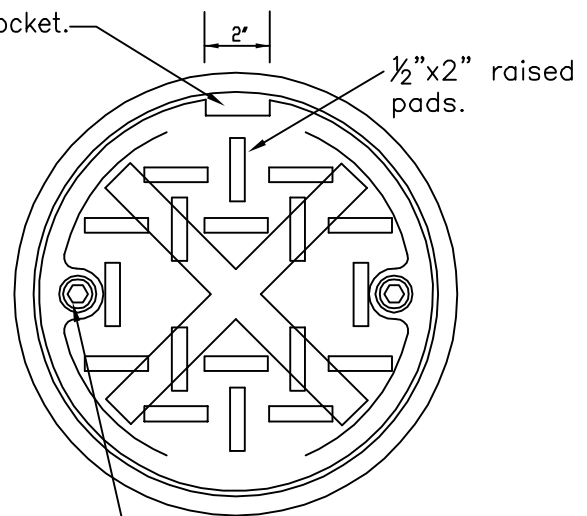

PLAN

Provide (2) $\frac{5}{8}$ " 11 N.C. socket head screws, $1\frac{1}{4}$ " long.

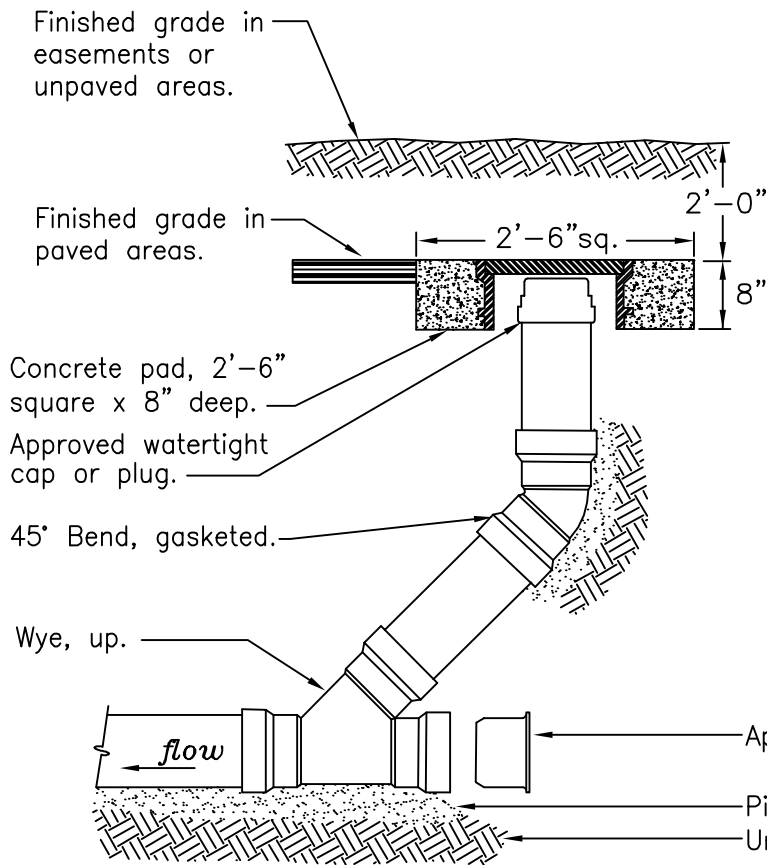

ELEVATION

Notes:

1. Cleanouts located in paved areas shall be brought to grade. In unpaved areas, bring pipe to within 2' of finished grade and place steel plate ($\frac{1}{8}$ " x 2' x 2')
2. Frame and cover shall be locking type, Olympic Foundry #M1025 or Sather 12" Lamphole.
3. All pipe material shall be bell & spigot type with rubber gasket joint and shall be in conformance with ASTM D3034 (SDR-35).

CLEAN-OUT

NOT TO SCALE

Detail Approvals
 Engineer GSM
 Manager DPK

**NORTHSHORE UTILITY DISTRICT
 STANDARD SEWER DETAILS**

8