

# Northshore Utility District

## 2024 SIDE SEWER SPECIFICATIONS

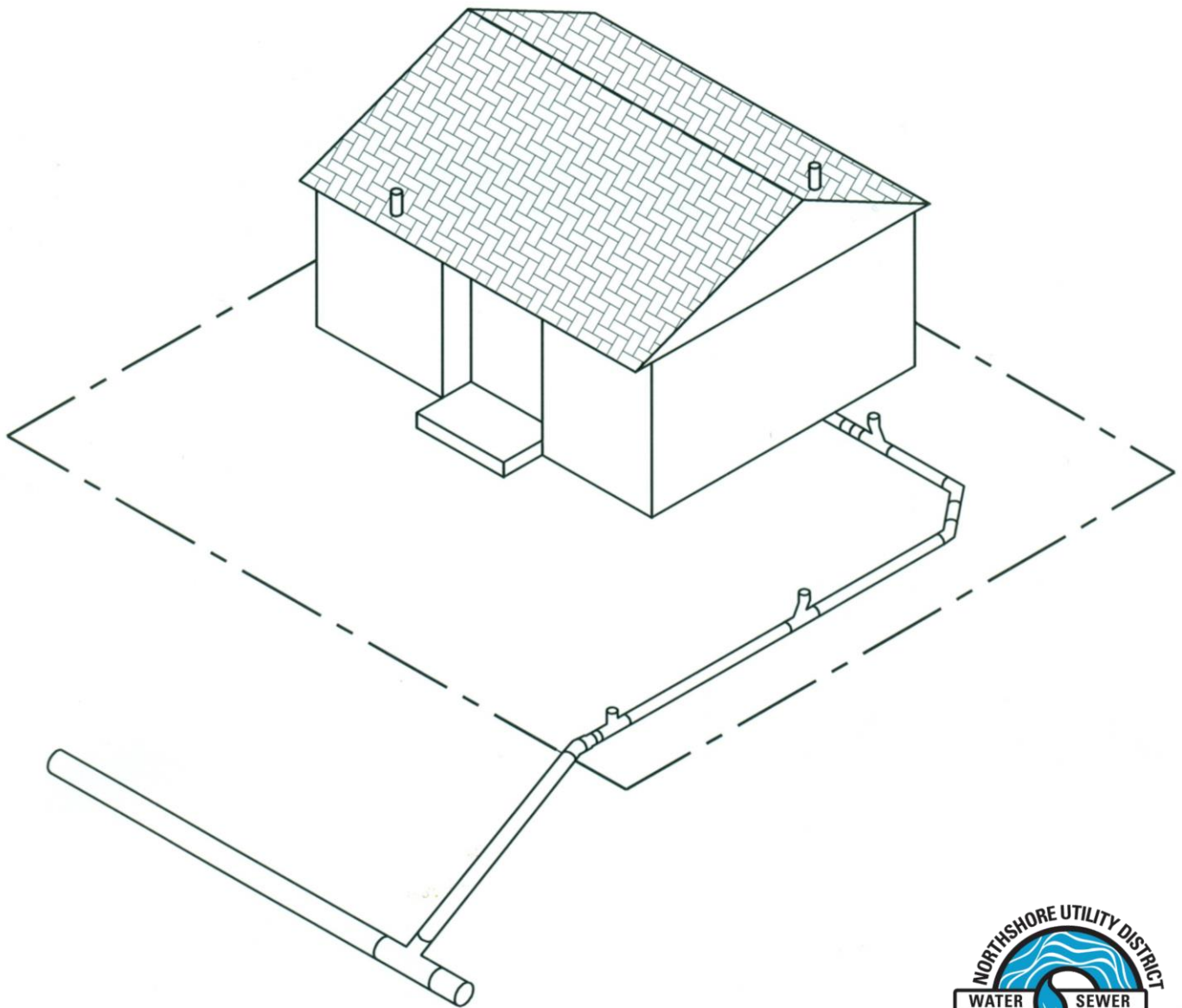

Updated MARCH 2024

# TABLE OF CONTENTS

---

---

## **SIDE SEWER SPECIFICATIONS**

SECTION 1	GENERAL.....	1
SECTION 2	APPLICATION, FORMS AND FEE REQUIREMENTS.....	1
	2.1. Application .....	1
	2.2. Connection Charges and Fees.....	2
	2.3. Site Plan .....	2
	2.4. King County Sewer Use Certification Form .....	2
	2.5. Owner Hold Harmless and License Agreement for SS Installation .....	2
	2.6. Restoration and Release.....	2
SECTION 3	EASEMENTS.....	3
SECTION 4	INSPECTION.....	3
SECTION 5	MATERIALS .....	4
	5.1. Pipe Bedding.....	4
	5.2. Trench Backfill .....	5
	5.3. Sewer Pipe and Fittings .....	5
	5.4. Manholes .....	6
SECTION 6	INSTALLATION .....	6
	6.1. Protection and Maintenance of Private Property .....	6
	6.2. Safety Standards .....	6
	6.3. Pipe Bedding and Trench Backfill.....	7
	6.4. Sewer Pipe Installation.....	7
	6.5. Cleanouts.....	9
	6.6. Steel Casings.....	9
	6.7. Grease Interceptors and Oil/water Separators .....	9
	6.8. Slip Lining and Pipe Bursting .....	9
SECTION 7	TESTING .....	10
	7.1. Water Test .....	10
	7.2. Low Pressure Air Test.....	10
	7.3. Manhole Vacuum Test .....	11
	7.4. Illegal Connections.....	11

## APPENDICES

TIPS TO PASS YOUR SIDE SEWER INSPECTION

SAMPLE SITE PLAN

SIDE SEWER SCHEMATIC

STANDARD DETAILS

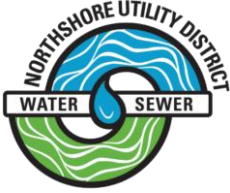

# SIDE SEWER SPECIFICATIONS

---

## 1. GENERAL

These specifications are intended to provide information for installation of side sewers on private property when connecting to the District's sanitary sewer system. For connections relating to work in the public right-of-way, please contact the District for project specific requirements.

The property owner ("Owner") of the connecting parcel shall be responsible for the completion of all forms and applications, payment of all charges and fees and shall comply with all District standards, details, requirements, and permit conditions.

A side sewer schematic is included in the appendix of this document which provides a general overview and visual guide for a typical side sewer installation.

## 2. APPLICATION, FORMS AND FEE REQUIREMENTS

### 2.1. APPLICATION

All sewer work being performed shall require completion of the District's Application for Side Sewer Permit. This form itemizes the conditions under which the District allows connection to its system.

The Contractor, acting as an agent of the Owner, shall complete and provide the following information to the District prior to commencing any work or receiving any permits:

- Certificate of Insurance
  - \$1,000,000 each occurrence Bodily Injury and Property Damage Liability.
  - \$2,000,000 annual aggregate
  - Northshore Utility District as Additional Insured and certificate holder
  - Include Additional Insured Endorsement
- Contractor's Application (if not already on file)

Contractors performing the work must be licensed, qualified and competent to provide such work including incidental work and work related to restoration of the site. Contractors who are unlicensed shall not be permitted to perform the installation of any sanitary sewer facility connecting to the District's collection system.



## 2.2. CONNECTION CHARGES AND FEES

All properties requesting new service shall complete the District's application and pay the District's current connection charges and fees at the time service is requested. Sewer service billing as established in the District's current rate resolution will commence once the side sewer is connected to the structure and has been approved by the District regardless of the status of water service.

## 2.3. SITE PLAN

A site plan shall be submitted with the application. The site plan shall indicate the proposed structure in relation to the property in a 1" =20' scale or a scale as approved by the District and be drawn in a clear and concise manner. Dimensions of the property and all sides or edges of the structure must be clearly shown. Also, the scale and north arrow must be indicated on the plan. Plan may be provided on 8 ½" x 11" or 8 ½" x 14" paper size. New construction must provide the approved site plan from the building permit. Refer to Sample Site Plan in the Appendix for additional information.

## 2.4. KING COUNTY SEWER USE CERTIFICATION FORM

All properties connecting to the sanitary sewer system for the first time are required to complete this document. The completed form is forwarded to King County which assesses a Sewage Treatment Capacity Charge against the property. This charge represents a share of the costs for the construction of King County's wastewater collection and treatment systems. King County bills the connecting property directly. For more information, please contact the King County Capacity Charge Program at (206) 296-1450.

## 2.5. OWNER HOLD HARMLESS AND LICENSE AGREEMENT FOR SIDE SEWER INSTALLATION

This document is a requirement for allowing the Owner to excavate and/or install their own side sewer line. The Owner will agree to hold the District harmless from loss or injuries suffered as a result of installing or making the side sewer connection.

## 2.6. RESTORATION AND RELEASE

When work occurs on adjacent property other than the Owners, a written release from the adjacent property Owner is required. The release states that the work was performed, and the area was restored to his/her satisfaction.



### **3. EASEMENTS**

Sanitary sewer lines that cross a property other than the one they serve are required to have easements. The easement form is provided by the District and shall be completed and signed by the burdened property owner(s) prior to the application being accepted by the District. The District will determine easement requirements during initial review of the application.

If a side sewer is to serve more than one property, a shared private side sewer easement is required insuring that all properties involved shall have perpetual use of and provisions for maintenance and access to the side sewer.

### **4. INSPECTION**

All work performed by the Contractor shall be inspected by a District representative. It shall be the responsibility of the Contractor to schedule the inspection by calling the number on the side sewer permit. A minimum of 24 hours notice is required to schedule an inspection. No side sewer trench shall be backfilled, or sewer pipe covered until the work has been inspected, tested, and approved by the District.

The District will inspect the work. However, nothing contained herein or elsewhere in these specifications shall be construed as requiring the District to direct the method or manner or safety of performing any work by the Contractor under these specifications. The District may reject all work and materials that, in the opinion of the District, do not conform to these specifications.

It is understood and agreed, by and between the parties hereto, that the work included in these specifications is to be done under the general observation and to the complete satisfaction of the District. The decision of the District as to the true interpretation and meaning of these specifications and as to all questions arising as to proper performance of the work shall be final.

District observers shall be present on the work site to observe the progress of the work and the manner in which it is being accomplished. Failure of the observer to call to the attention of the Contractor faulty work or deviations from the specifications shall not constitute acceptance of the work.

All work performed, and all materials and equipment furnished, and the manufacture and preparation thereof, shall be subject to review by the District. For the purpose of inspection, the District shall at all times have access to all parts of the work. The Contractor shall, at all times, maintain proper facilities and provide safe access for such review. The District may reject or accept material and equipment to be incorporated in the work. However, the failure of the District to reject defective material, or any other work involving deviations, will not constitute acceptance of such work. The presence or absence of an observer on the job shall not relieve the Contractor of its obligation to furnish satisfactory materials and



workmanship. Should any work be backfilled without approval or consent of the District it must be uncovered for examination at the Contractor's expense.

The Contractor shall regard and obey the directions and instructions of the District with reference to correcting any defective work or replacing any materials found to be not in accordance with the specifications and plans and, in case of dispute, the Contractor may appeal to the District whose decision shall be final; but, pending such decision, the instructions shall be followed, and the Contractor shall make no claims on this account.

## 5. MATERIALS

The Contractor shall furnish all materials for the completion of work to be performed in conformance with these specifications and shall be fully responsible for all materials until the completed project is installed, inspected and approved by the District.

Contractor shall protect materials against damage from careless handling, exposure to weather, mixture with foreign matter and all other causes. The District will reject and refuse to test materials improperly handled or stored.

All materials furnished shall be warranted by the Contractor as new and in accordance with the specifications and as suitable for the intended purpose. The type and class of materials to be used shall be in accordance with the specifications referenced herein. All materials shall be new and undamaged of a known brand, with replacement parts readily available from the general Seattle area.

### 5.1. PIPE BEDDING

Bedding material shall consist of clean, granular, manufactured pea gravel conforming to the following gradation:

U. S. Standard Sieve Size	% Passing by Weight
1/2"	100
3/8"	85 – 95
No. 4	5 – 15
No. 8	0 – 2

Recycled concrete will not be allowed as pipe bedding.



## 5.2. TRENCH BACKFILL

Native material may be used on private property and easements if 90% compaction can be attained. If directed by the District, import backfill material may be required at locations where the side sewer is installed under driveways, within paved access tracts or where 95% compaction is required. No wood debris, large rocks or other unsuitable debris will be allowed in the backfill material. Recycled concrete will not be allowed as trench backfill.

## 5.3. SEWER PIPE AND FITTINGS

Sewer pipe material shall be PVC unless special conditions (beneath rockeries, streams, wetlands, steep slopes, shallow or deep installations, unstable soil, etc.) require the use of restrained joint ductile iron pipe, per Section 5.03B below.

### A. PVC SEWER PIPE AND FITTINGS

All PVC pipe and fittings shall be integral wall bell and spigot, rubber gasket joint, unplasticized polyvinyl chloride (PVC) pipe in conformance with ASTM D3034 and shall have a maximum Standard Dimension Ratio (SDR) of 35. PVC pipe shall have a minimum "pipe stiffness" of 46 psi at 5 percent deflection when tested in accordance with ASTM Designation D2412 and a minimum impact strength of 210 foot-pounds based upon ASTM D3034.

All pipes shall be clearly marked with the manufactures identification, year, and class of pipe.

All fittings and accessories shall be manufactured and furnished by the pipe supplier or shall be District approved equal.

Pipe joints shall use flexible elastomeric gaskets conforming to ASTM D3212.

### B. DUCTILE IRON SEWER PIPE AND FITTINGS

Ductile iron pipe shall be new, Class 52, cement-lined, conforming to AWWA C151.

Ductile iron pipe shall be push-on joint. Pipe shall be furnished with a single rubber ring gasket lubricated to affect the seal. Each length of pipe shall be clearly marked with the manufactures identification, year, thickness, class of pipe and weight.

Restrained joint pipe (if required) shall be push-on joint pipe with U.S. Pipe "TR Flex" or U.S. Pipe "Field Lok" gaskets, or equal.

Each length of pipe shall be clearly marked with the manufactures identification, year, thickness, class of pipe and weight.

Ductile iron fittings shall be short body with a 350-psi pressure rating for mechanical joint fittings and 250 psi for flanged fittings. All fittings shall be cement lined and shall be in conformance with AWWA C153.



## 5.4. MANHOLES

Manholes shall be of the offset type (unless otherwise noted), shall be precast concrete sections with a precast base, and shall be made from 3,000 psi structural concrete. All manhole joints shall be watertight and shall be confined O-ring type. Manholes shall be constructed in full compliance with the Standard Details and Specifications. Manhole covers for Private Owned Manholes shall not include the District name or logo.

## 6. INSTALLATION

Side sewer installation shall be in accordance with adopted standards and details of Northshore Utility District, the manufacturer's recommendation, and these side sewer specifications. Refer to Side Sewer Schematic in the Appendix for additional information.

### 6.1. PROTECTION AND MAINTENANCE OF PRIVATE PROPERTY

The Contractor shall protect and maintain all underground and above-ground utilities and structures affected by the work and all lawns, shrubs, fences, rockeries, etc. on private property. It shall be the responsibility of the Contractor to call for utility locates prior to construction. Any damage shall be repaired and restored by the Contractor to the satisfaction of the District and property Owner.

The Contractor shall protect and maintain any natural watercourse that exists prior to construction in accordance with any permits issued for the project.

Construction work on easements shall be confined to the limits of the easements and accomplished so as to cause the least amount of disturbance and a minimum amount of damage.

***It is expressly understood that the Contractor shall in particular restore all easements to a condition equal to its original condition, or superior, and in a condition satisfactory to the District and property owner.***

Where the work is done within easements, the Contractor shall obtain a written statement of satisfactory restoration (Restoration Release Form, provided by the District) from each property owner involved and furnish a copy of the signed form to the District. The signed Restoration Release Form shall be required before the work will be accepted by the District.

### 6.2. SAFETY STANDARDS

In accordance with generally accepted construction practices, the Contractor will be solely and completely responsible for conditions of the job site during performance of the work, including safety of all persons and property. This requirement will apply continuously and not be limited to normal working hours.





The Contractor shall adhere to the requirements of the Occupational Safety and Health Act (OSHA), Washington Industrial Safety and Health Act, and all other Federal, State, and local safety and health statutes, which may apply.

Contractor shall provide and install trench safety systems such as shoring or trench boxes or shall employ construction techniques such as back-sloping that meet the applicable Federal, State and Local safety regulations.

### 6.3. PIPE BEDDING AND TRENCH BACKFILL

Pipe bedding material shall be carefully placed and firmly compacted to provide a firm, uniform cradle for the full length of pipe being installed. The minimum thickness of the layer of bedding material required beneath the pipe shall be four (4) inches. After the pipe laying operation, additional bedding material shall be placed over the pipe to a minimum height of six (6) inches above the pipe.

Trench backfill shall be placed only after the sewer pipe has been inspected, tested, and approved by the District. In backfilling the trench, the Contractor shall take all necessary precautions to protect the pipe from any damage or shifting of the pipe.

### 6.4. SEWER PIPE INSTALLATION

All connections shall be made to the side sewer stub assigned to that property and no stub belonging to another property shall be used unless approved by the District. Connecting properties are to have individual, single side sewers four (4) inches in diameter. Side sewers on easements shall be a minimum of six (6) inches in diameter.

The District may allow additional properties connected to a single side sewer stub only if approved by the District. If additional properties are allowed, the common line portion of the side sewer is to be six (6) inches in diameter. Other requirements such as manholes, cleanouts, point of connection, etc. will be determined during the application review and as required for site specific conditions.

Commercial establishments, schools, or any building other than single family residences shall be six (6) inches in diameter. Only one commercial building will be allowed to connect to a 6-inch line. A minimum length of five (5) feet of six (6) inch diameter pipe must be used where the side sewer connects to the main line.

A 10-foot horizontal separation and 18-inch vertical separation is to be maintained between all proposed sewer lines and water lines. If the 10-foot horizontal separation cannot be achieved due to unusual conditions or site-specific restrictions, the District may allow the separation to be reduced to 5 feet, provided that the lines are laid in a separate trench and 18 inches of vertical separation is maintained. The minimum separation between other utilities (gas, power, phone, cable, storm, etc.) shall be three (3) feet.

When it is necessary for sewer and water lines to cross each other, the crossing shall be made as closely to a 90° angle as possible, and the sewer line shall be located three or more feet below the water line.



Side sewers shall have a minimum depth of six (6) feet below final ground elevation at the property line and a minimum depth of eighteen (18) inches of cover over the pipe once inside the property.

The maximum bend permissible for a side sewer at anyone fitting shall not exceed 45°. Bends exceeding 45° with any combination of two fittings shall have a straight section of pipe not less than two (2) feet in length installed between the fittings, unless one fitting is a wye branch with a cleanout provided on the straight leg.

Unless otherwise approved by the District, the sewer pipe shall be installed upgrade from point of connection on the existing sewer or from a designated starting point. The sewer pipe shall be installed with the bell end forward or upgrade. When pipe laying is not in progress, the forward end of the pipe shall be kept tightly closed with an approved temporary plug. All side sewers shall be laid at a minimum two (2) percent and maximum 100 percent (45 degree) slope. The District may, at its own discretion, allow installation of side sewers to be less than two percent under certain circumstances upon the owner's signing a Release of Liability and Hold Harmless Agreement. Side sewers installed on steep slopes, in unstable material, within steel casings, in sensitive areas, or as directed by the District will require the use of restrained joint ductile iron pipe.

Pipe joints shall be installed in strict compliance with the manufacturer's recommendations. Care shall be taken to properly clean and lubricate the spigot, gasket, and socket of the pipe before joining. The pipe spigot shall be forced into the socket until the reference mark on the spigot is flush with the bell end. Forcing the pipes together beyond this point prevents proper contraction and expansion at the joints.

Pipe or pipe fittings that are damaged will be rejected and required to be replaced. Ductile iron pipe that has damage to the interior cement lining will also be rejected. At the District's discretion, ductile iron pipe may be required when minimum cover cannot be achieved or when surface loading precludes the use of PVC pipe.

If ductile iron pipe is to be connected to PVC pipe, a PVC to ductile iron Romac transition coupling is required. Romac couplings will also be required when connecting other dissimilar pipe types with the exception to the plumbing connection, or ABS pipe connection as shown in Standard Sewer Details 17 and 18, where a Strongback Fernco is allowed.

For all 6" or larger side sewer pipe installs, 3" wide, green metallic side sewer detector tape shall be laid 24" above the pipe bedding for the entire length of the pipe installed. Identification on the tape shall include the words "Sanitary Sewer".

If gravity flow is not available, and the District has determined that there are no other alternative methods for gravity service, a sanitary sewer grinder pump station may be allowed. All pumping equipment and accessories shall be standard manufactured items specifically for sewage use in accordance with the Standard Details. The Contractor shall submit to the District a plan showing the location of the station, shop drawings, details, and pump performance curve data prior to installation. As a condition for allowing



a grinder pump station, the District will require that a Pump Agreement be signed by the Owner and recorded against the property.

#### 6.5. CLEANOUTS

For single-family residences, surface cleanouts shall be required at a minimum of every 100 feet, as shown per Standard Sewer Detail 9. For commercial properties, cleanouts shall be installed at locations designated by the District, but in no case, shall they exceed 100 feet. Additional cleanouts may be required at bends as determined by the District. Cleanouts shall be installed in accordance with the Standard Details.

#### 6.6. STEEL CASINGS

Any side sewer installed under rockeries or walls or as directed by the District must be installed within a steel casing in accordance with the Standard Details.

#### 6.7. GREASE INTERCEPTORS AND OIL/WATER SEPARATORS

No grease, oil, sand, contaminated liquid, or other harmful material will be allowed into the District's sewer system without the installation of a grease interceptor or oil/water separator. The interceptor or separator is to be designed to accommodate the anticipated flows. Sizing calculations, layout plan and the location of the connection point to the sewer is required to be submitted to the District for review and be in accordance with the appropriate city jurisdiction and the District's approved policy on Fats, Oils and Grease (F.O.G.) program. Interceptors or separators shall be maintained by the property owner and shall be in continuous operation at all times and be accessible for routine inspection.

#### 6.8. SEWER SLIP LINING AND PIPE BURSTING

Prior to the installation of a slip-liner (Cured In-Place Pipe, CIPP), the Contractor shall perform a video inspection of the sewer designated to receive the liner. The pre-liner video is to be provided to the District's inspector on a flash drive at the time of inspection. At locations where the CIPP liner fully passes through a connection of dissimilar pipes, a Strongback Fernco will be allowed in lieu of the Romac 501 coupler.

The District does not generally allow pipe bursting for side sewer installations or repairs. Exceptions may be made on a case-by-case basis. To request an exception, the Contractor shall submit plans detailing methods and materials of construction to the District for review and approval.



## 7. TESTING

The entire side sewer line being installed from the existing sewer stub to the proposed structure(s) shall be under the District's observation.

Before sewer lines are accepted, all lines shall be tested, and corrections of any deficiencies shall be made at the expense of the Contractor. The Contractor shall test the entire length of sewer pipe installed using one of the following test methods:

### 7.1. WATER TEST

A 6" test tee shall be installed at the end of the 6" stub and an approved plug installed in the test tee. A 4" wye with a minimum 6' tall riser pipe shall be installed approximately 3' from the proposed structure at the upper end of the side sewer. Backfill shall only be placed to secure the pipe at the upstream and downstream of the pipe segment being tested. The side sewer shall be filled with water at the upper end until the entire pipe system is full, and the upper end riser pipe will not accept any additional water. The side sewer will be visually inspected by the District to determine if leakage occurs. Once the pipe system has been filled, the water test will commence for 10 minutes. The Contractor shall repair all defective work. If there is no evidence of leakage, the Contractor may then backfill the pipe and the test will be considered acceptable.

### 7.2. LOW PRESSURE AIR TEST

The low-pressure air test shall be in accordance with Section 7-17.3(2)F, *Low Pressure Air Test for Sanitary Sewers Constructed of Non-Air-Permeable Materials*, of the latest published Standard Specifications for Road, Bridge and Municipal Construction of the Washington State Department of Transportation. The Contractor shall furnish all equipment and personnel for conducting the air test under the supervision of the District. The Contractor may desire to make an air test prior to backfilling for his own purposes. However, the acceptance air test shall be made after backfilling has been completed and compacted.

All wyes, tees, or the end of the side sewer shall be plugged with flexible joint caps or acceptable alternative, securely fastened to withstand the internal test pressures.

Air shall be slowly supplied to the plugged pipe installation until the internal air pressure reaches 4.0 pounds per square inch. At least two minutes shall be allowed for temperature stabilization before proceeding further.

The requirements of this specification shall be considered satisfied if the time required in seconds for the pressure to decrease from 3.5 to 2.5 lbs. per square inch is not less than the listed values shown in the following table:

**Allowable Time for Low Pressure Air Test**

Diameter (inches)	Min. Test Times for Length of Main (seconds)				
	50'	100'	150'	200'	250'
4	36	72	108	144	178
6	80	160	240	320	400

Note: All test times in the above table are rounded up to the nearest even number.

The use of air pressure for testing sewer lines creates hazards that must be recognized. The Contractor shall be certain that all plugs are securely blocked to prevent blowouts. The air testing apparatus shall be equipped with a pressure release device such as a rupture disc or a pressure relief valve designed to relieve pressure in the pipe if it exceeds the required test pressure.

***Precautions shall be taken to prevent any damage caused by testing. Any damage resulting shall be repaired by the Contractor at his own expense.***

**7.3. MANHOLE VACUUM TEST**

All newly installed manholes shall be vacuum tested in accordance with ASTM C1244-05 to verify water tightness. All manhole penetrations shall be blocked or sealed and braced prior to the testing in order to prevent pipes, boots, gaskets, or other materials from being drawn into the manhole. A vacuum of ten (10) inches of Hg shall be drawn on the manhole and the vacuum pump shut off. The time for the vacuum on the manhole to drop from ten (10) inches of Hg to nine (9) shall be measured and the manhole shall have passed the vacuum test if the time measured is greater than shown on the following table. Vacuum tests shall be performed under the observation of the District's inspector.

**Minimum Test Times for MH Vacuum Testing**

MH Diameter (inches)	Depth (feet)								
	8 or less	10	12	14	16	18	20	22	24
	Time (seconds)								
48	20	25	30	35	40	45	50	55	59
54	23	29	35	41	46	52	53	64	64

If the time required for the pressure to drop from 10 inches of Hg to 9 inches of Hg is less than the value indicated in the table, the manhole shall be rejected by the District and shall be repaired or replaced and re-tested by the Contractor.

**7.4. ILLEGAL CONNECTIONS**

It shall be unlawful to disconnect, remove or install any portion of the sewer piping without securing a permit and obtaining prior approval from the District. Any line to be disconnected shall be approved by the District and will require the line to be plugged at the location as determined by the District.



# **APPENDICES**

TIPS TO PASS YOUR SIDE SEWER INSPECTION

SAMPLE SITE PLAN

SIDE SEWER SCHEMATIC

STANDARD SEWER DETAILS



## **PASSING YOUR SIDE SEWER INSPECTION**

Side sewer permits and inspections are required for all sewer work on private property and in the right-of-way, including new installations, alterations, repairs, pipe lining, capping, relocations, and removals.

Failing your side sewer inspection is costly and time consuming. Reinspection trips due to the contractor's inability to have work ready for inspection at the scheduled inspection appointment, poor workmanship, or failure to comply with the regulations and construction requirements of the District, may result in additional inspection fees charged to the contractor. Please review these helpful tips for passing your side sewer inspection.

### **1. READ THE SIDE SEWER SPECIFICATIONS BOOKLET.**

- The District's requirements are spelled out in detail in the specification's booklet. Most questions have already been addressed including pipe types, bedding material, installation, and repair requirements. Additional questions can be directed to the Engineering Department by calling 425.398.4401 or emailing [permits@nud.net](mailto:permits@nud.net).

### **2. BE ON SITE DURING YOUR SCHEDULED INSPECTION TIME.**

- The District's inspector requires that you are present during your scheduled inspection. Inspections can be scheduled for the morning or afternoon. Morning inspections are between 8am and noon; afternoon inspections are from 1:00pm to 3:30pm. The inspector does not make phone calls on the road. If no one is on site when the inspector arrives, the inspection will be given an automatic fail and reinspection fees will apply. Your printed permit must be on site at the time of inspection.

### **3. ALL WORK MUST BE COMPLETE AND LEFT UNCOVERED FOR VISUAL INSPECTION.**

- All installation and repair work must be complete, including the connection to the building, and under test (if applicable) when the inspector arrives. Photos of sewer work will not be accepted. Any work that is backfilled without the District's approval must be uncovered. Additional inspections required for incomplete work will be subject to reinspection fees.

### **4. NO FERNCO OR STRONG BACK COUPLINGS.**

- The District does not allow pipe connections to be made using Fernco or Strong Back couplings (the only exceptions are at the building's plumbing connection, see Standard Sewer Detail 8b, or ABS pipe connection as shown in Standard Sewer Details 17 and 18). All dissimilar pipe connections must be made using Romac or Ford couplings.

### **5. MAKE SURE ALL REQUIRED MATERIALS OF CONSTRUCTION ARE ON SITE.**

- The District's inspector must visually inspect all construction materials to ensure they comply with the District's side sewer specifications and details. Materials such as clean-out boxes and mechanical plugs that cannot be installed at the time of inspection must be on site. Missing materials will constitute failure to comply with the District's construction standards and result in a failed inspection.

Most side sewer inspections called in before 4:30pm can be scheduled for the next day. Inspection requests made after 4:30pm will be scheduled out 48 hours. The District cannot accommodate same day inspection requests. To schedule your side sewer inspection, call 425.398.4401 or email [permits@nud.net](mailto:permits@nud.net).

Property Address \_\_\_\_\_

Tax ID Number \_\_\_\_\_

Legal Description \_\_\_\_\_

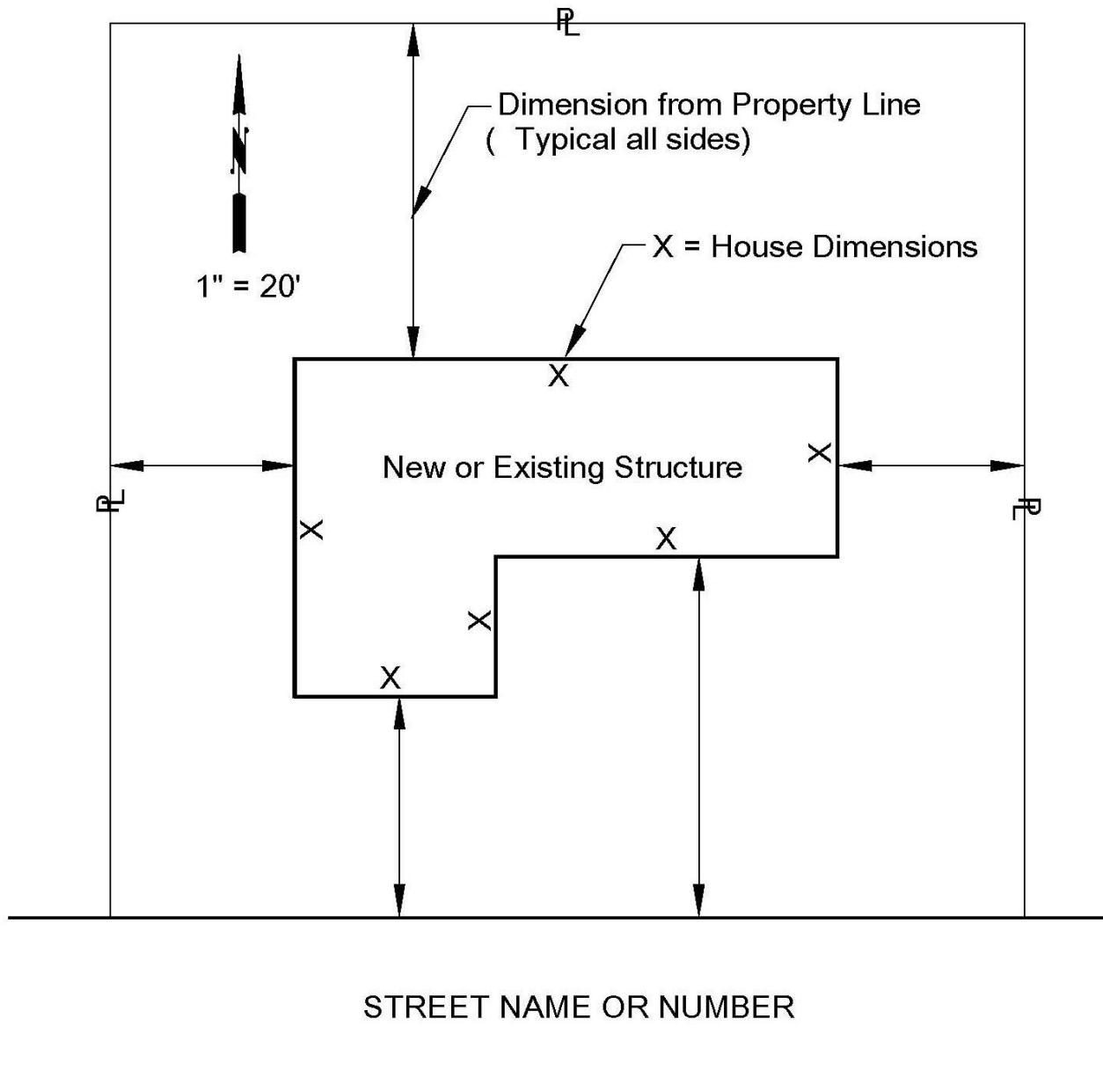

## SAMPLE SITE PLAN

SEE SECTION 2.3 FOR ADDITIONAL DETAILS REGARDING THE SITE PLAN



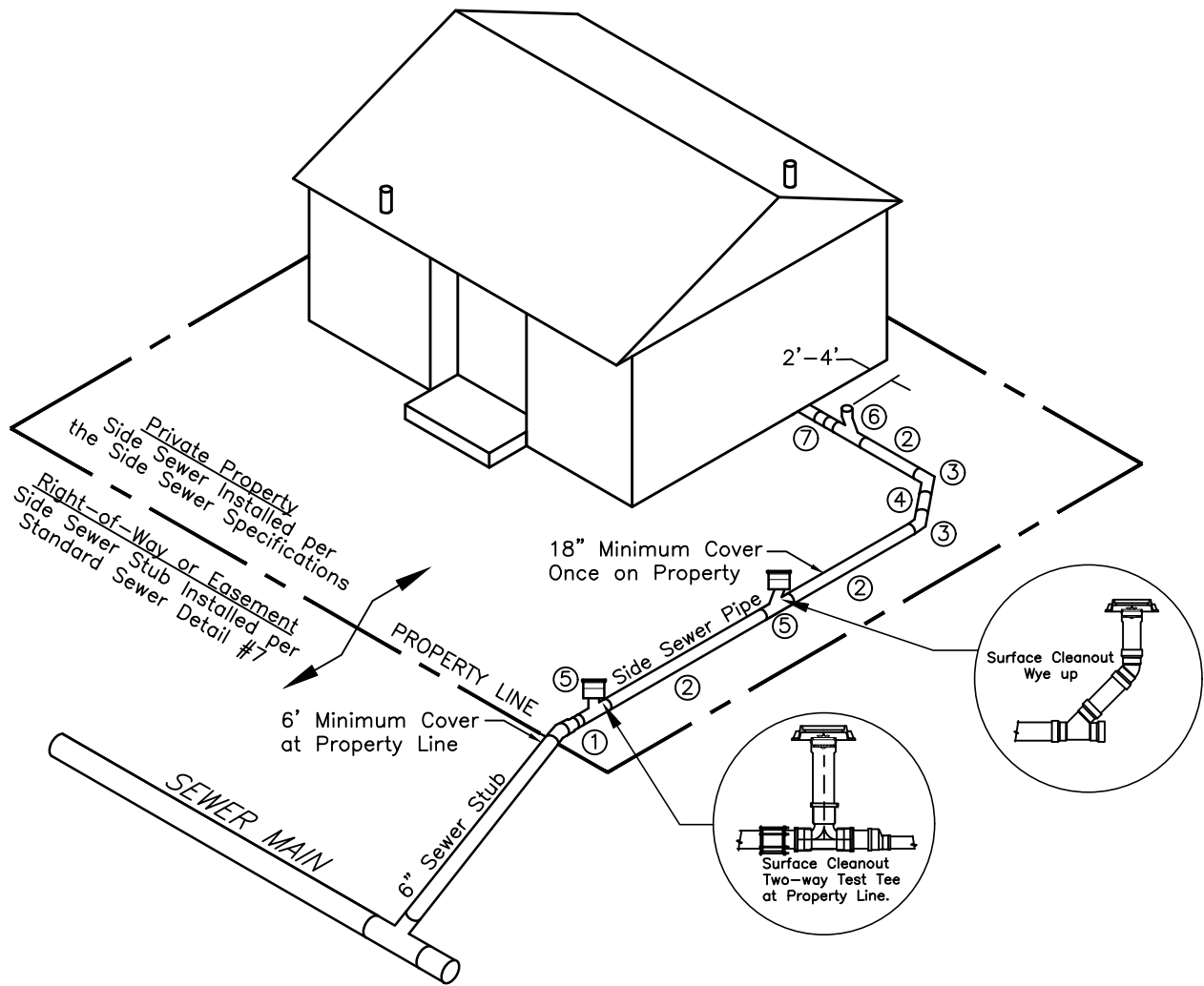

- ① CONNECT TO EXISTING 6" SEWER STUB. SEE STANDARD SEWER DETAIL 8a.
- ② 4" SIDE SEWER PIPE AT 2% MINIMUM SLOPE (6" MINIMUM PIPE FOR NON-RESIDENTIAL AND WITHIN EASEMENTS). PIPE SHALL BE PVC ASTM D3034, BEDDED IN PEA GRAVEL.
- ③ 45° MAXIMUM BEND.
- ④ 2' MINIMUM LENGTH OF PIPE BETWEEN BENDS.
- ⑤ SURFACE CLEANOUT AT PROPERTY LINE (OR EDGE OF EASEMENT) AND EVERY 100' AS REQUIRED.
- ⑥ CLEANOUT AT HOUSE CONNECTION MAY BE BURIED AND BROUGHT TO WITHIN 24" OF GRADE. SEE STANDARD SEWER DETAIL 8b.
- ⑦ APPROVED ADAPTER AT PLUMBING CONNECTION (STRONG BACK FERNCO OR EQUAL).

**NOTE:**  
 REFER TO NORTHSORE UTILITY DISTRICT'S SIDE SEWER SPECIFICATIONS FOR ADDITIONAL INFORMATION.

## **SIDE SEWER SCHEMATIC**

NOT TO SCALE

GROUT ADJUSTING RINGS INSIDE, OUTSIDE AND BETWEEN. GROUT UNDER CASTING. INSIDE GROUT SHALL HAVE A SMOOTH BROOM FINISH.

MANHOLE FRAME AND COVER PER THE STANDARD SEWER DETAIL #5. LOCATE AS SHOWN ON PLAN.

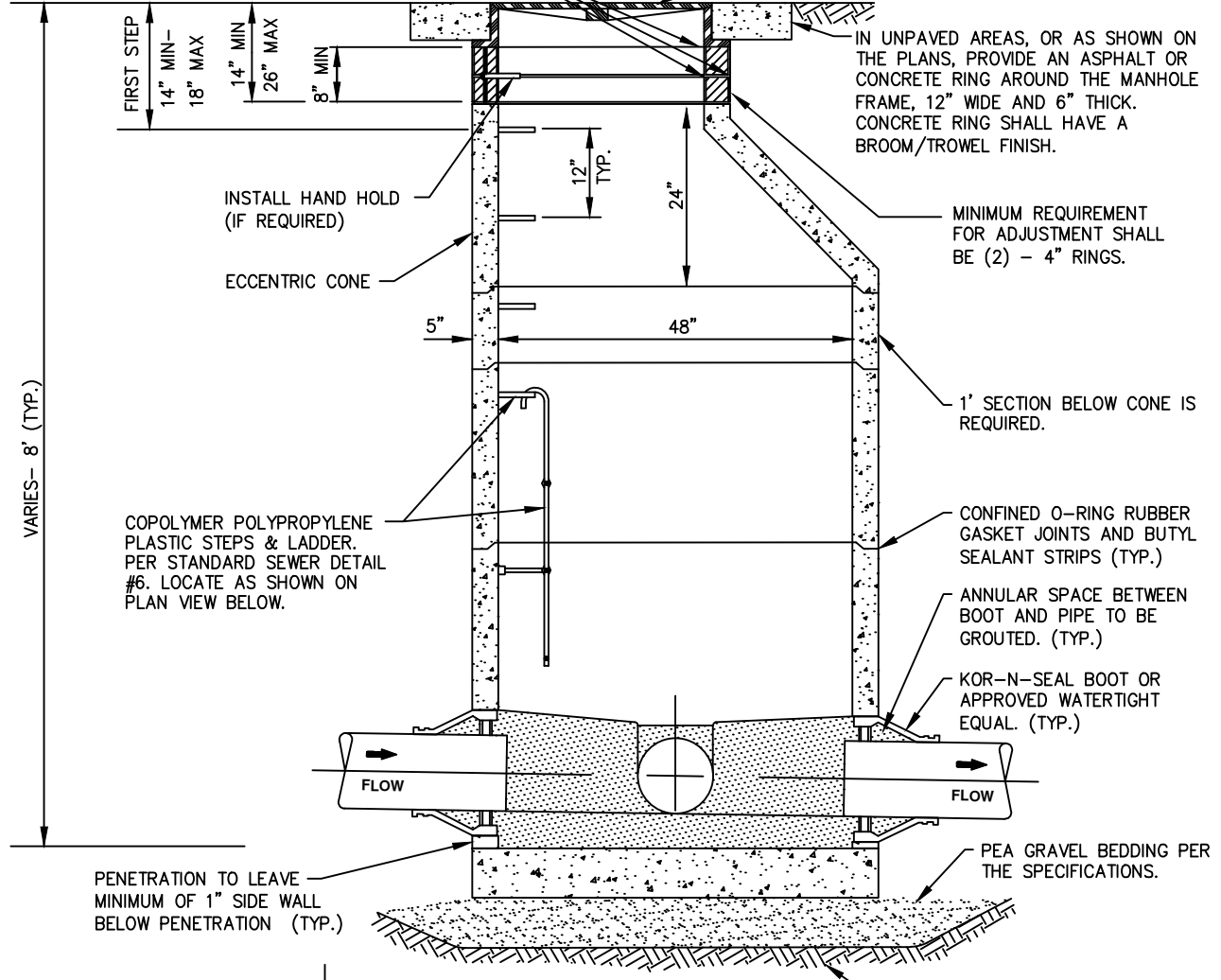

VARIES- 8' (TYP.)

FIRST STEP  
14" MIN- 18" MAX  
14" MIN 26" MAX  
8" MIN

INSTALL HAND HOLD (IF REQUIRED)  
ECCENTRIC CONE

COPOLYMER POLYPROPYLENE PLASTIC STEPS & LADDER. PER STANDARD SEWER DETAIL #6. LOCATE AS SHOWN ON PLAN VIEW BELOW.

IN UNPAVED AREAS, OR AS SHOWN ON THE PLANS, PROVIDE AN ASPHALT OR CONCRETE RING AROUND THE MANHOLE FRAME, 12" WIDE AND 6" THICK. CONCRETE RING SHALL HAVE A BROOM/TROWEL FINISH.

MINIMUM REQUIREMENT FOR ADJUSTMENT SHALL BE (2) - 4" RINGS.

1' SECTION BELOW CONE IS REQUIRED.

CONFINED O-RING RUBBER GASKET JOINTS AND BUTYL SEALANT STRIPS (TYP.)

ANNULAR SPACE BETWEEN BOOT AND PIPE TO BE GROUTED. (TYP.)

KOR-N-SEAL BOOT OR APPROVED WATERTIGHT EQUAL. (TYP.)

PENETRATION TO LEAVE MINIMUM OF 1" SIDE WALL BELOW PENETRATION (TYP.)

PEA GRAVEL BEDDING PER THE SPECIFICATIONS.

FOUNDATION GRAVEL PER THE SPECIFICATIONS, IF REQUIRED.

**SECTION A-A**

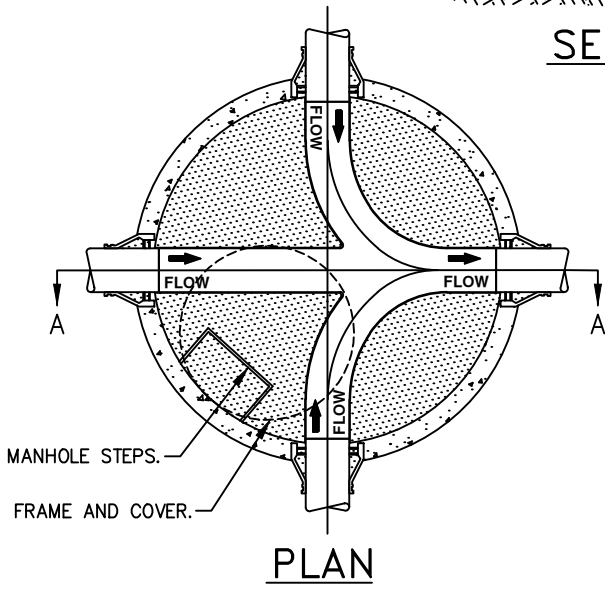

**PLAN**

**NOTES:**

1. MANHOLE BASE SHALL BE CONCRETE CHanneled PER THE ENGINEERING SPECIFICATIONS. SLOPE SHALL BE A MINIMUM OF 0.1' ACROSS THE INVERT CHANNEL.
2. MARKER POSTS MAY BE REQUIRED IN EASEMENTS.
3. FOR MANHOLES LESS THAN 5' IN DEPTH, SEE SEWER STANDARD DETAIL #3, SHALLOW MANHOLE AND SEWER STANDARD DETAIL #16, EXTRA SHALLOW MANHOLE.
4. ALL PICK HOLES SHALL BE GROUTED ON THE INSIDE AND OUTSIDE OF MANHOLE.
5. MANHOLE LID SHALL BE ORIENTED PER THE DISTRICT'S DIRECTION.

**PRECAST MANHOLE**

NOT TO SCALE

<b>DETAIL APPROVALS</b>	
<b>EDITOR</b>	TMC
<b>MANAGER</b>	EM

**NORTHSHORE UTILITY DISTRICT**  
2024 STANDARD SEWER DETAILS

**1**

LAST UPDATED  
MARCH 2024





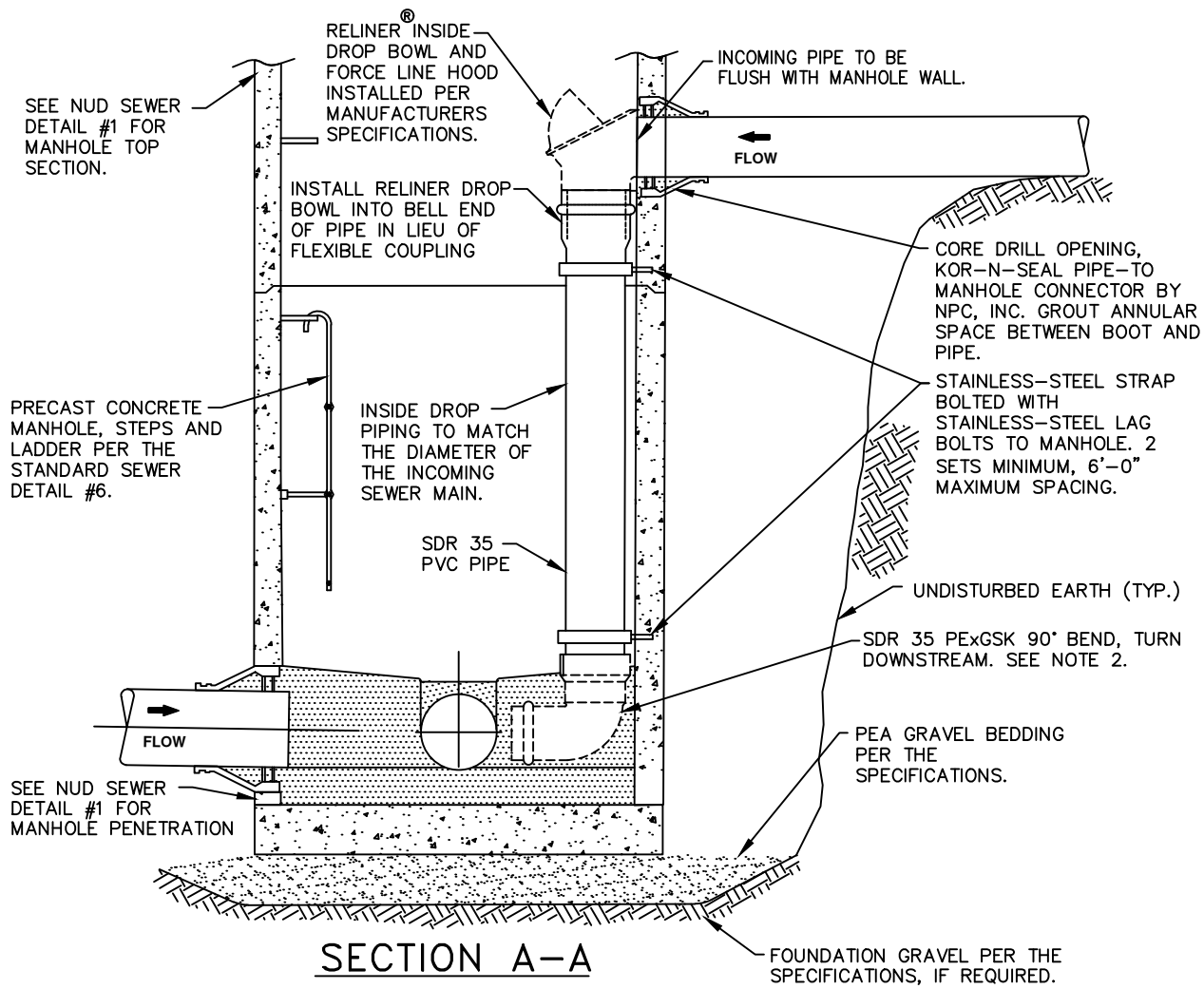

**SECTION A-A**

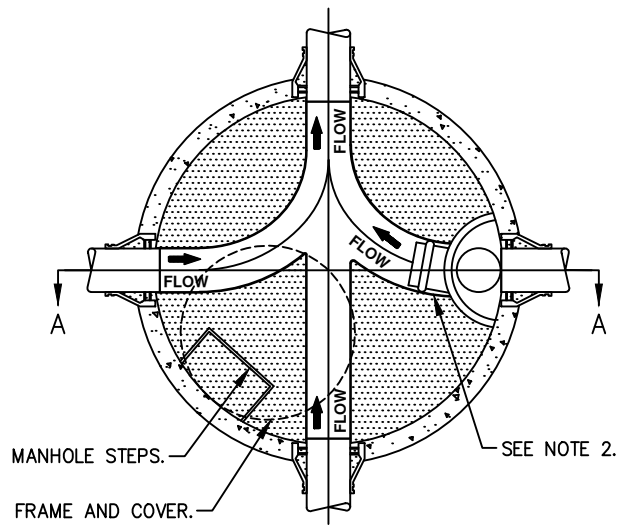

**PLAN**

**NOTES:**

1. DROP MANHOLES ARE ONLY ALLOWED WITH DISTRICT APPROVAL.
2. THE MANHOLE BASE SHALL BE CONCRETE CHanneLED PER THE ENGINEERING SPECIFICATIONS. SLOPE SHALL BE A MINIMUM OF 0.1' ACROSS THE INVERT CHANNEL.
3. CHANNEL RECEIVING THE INSIDE DROP FLOW SHALL BE SIZED ONE PIPE SIZE LARGER THAN THE INCOMING PIPE TO ACCOMMODATE THE 90° BEND. BEND TO REST FLUSH IN THE CHANNEL.
4. EXISTING MANHOLES SHALL HAVE THE BEND SET ON TOP OF THE EXISTING BENCH, ORIENTED TOWARDS THE DOWNSTREAM OUTLET, AND GROUTED IN-PLACE. ADDITIONAL PVC PIPE MAY BE REQUIRED TO DIRECT FLOW TO THE DOWNSTREAM OUTLET.
5. MARKER POSTS MAY BE REQUIRED IN EASEMENTS.
6. ALL PICK HOLES SHALL BE GROUTED ON THE INSIDE AND OUTSIDE OF MANHOLE.
7. MANHOLE LID SHALL BE ORIENTED PER THE DISTRICT'S DIRECTION.

**INSIDE DROP MANHOLE**

NOT TO SCALE

<b>DETAIL APPROVALS</b>	
<b>EDITOR</b>	TMC
<b>MANAGER</b>	EM

**NORTHSHORE UTILITY DISTRICT**  
2024 STANDARD SEWER DETAILS

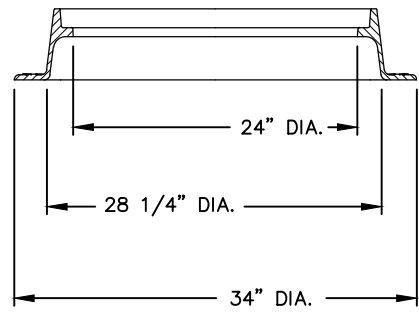
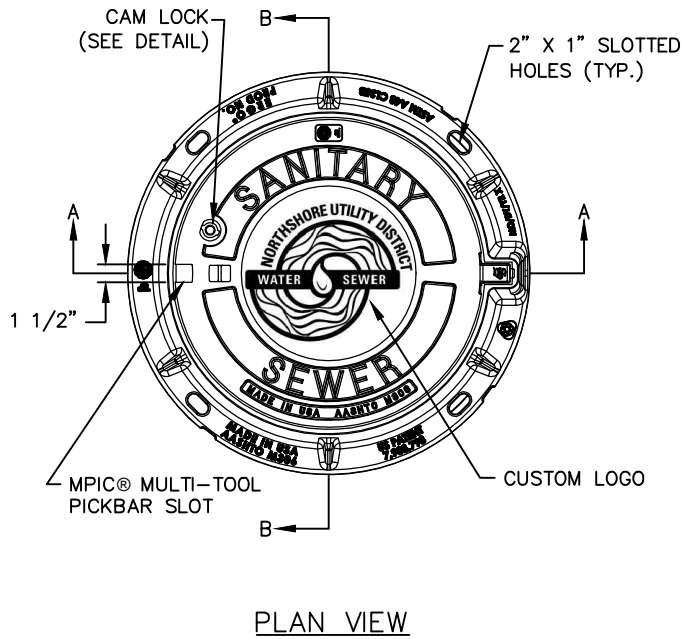

FRAME SECTION B-B

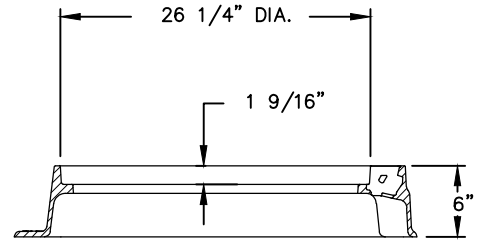

FRAME SECTION A-A

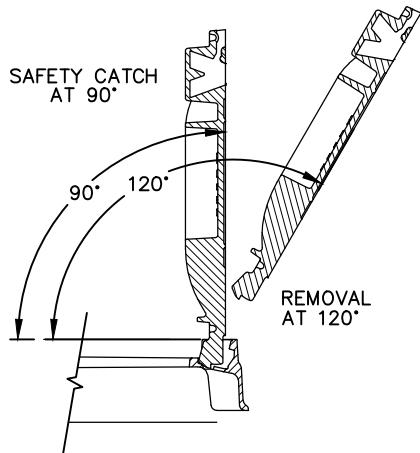

HINGE POSITIONS

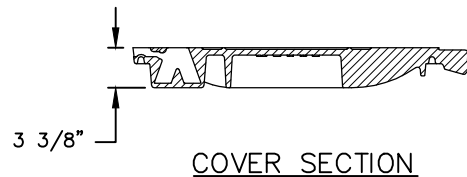

COVER SECTION

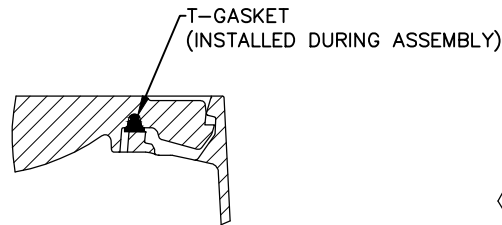

HINGE & GASKET VIEW

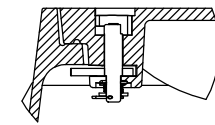

CAM LOCK VIEW

**NOTE:**

1. MANHOLE FRAME AND COVER SHALL BE EAST JORDAN IRON WORKS ERGO ASSEMBLY, PART NUMBER 001040105L01.
2. FOR PRIVATE MANHOLES, FRAME AND COVER SHALL BE EAST JORDAN IRON WORKS ERGO ASSEMBLY, PART NUMBER 00104043L01. MANHOLE LID TO SAY "SEWER". MANHOLE LID NOT TO INCLUDE NUD LOGO OR NAME.

**MANHOLE LOCKING FRAME AND COVER**

NOT TO SCALE

**DETAIL APPROVALS**  
**EDITOR** TMC  
**MANAGER** SJD

**NORTHSHORE UTILITY DISTRICT**  
 2024 STANDARD SEWER DETAILS

**5**

LAST UPDATED  
 FEBRUARY 2020

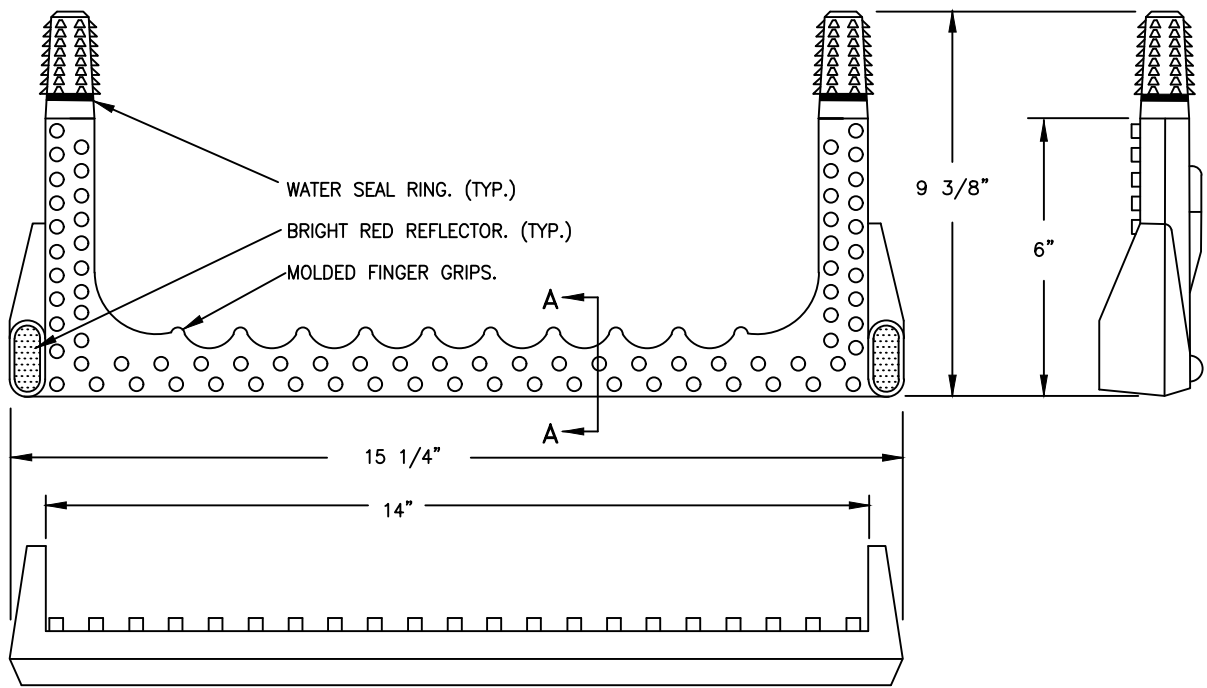

STEP

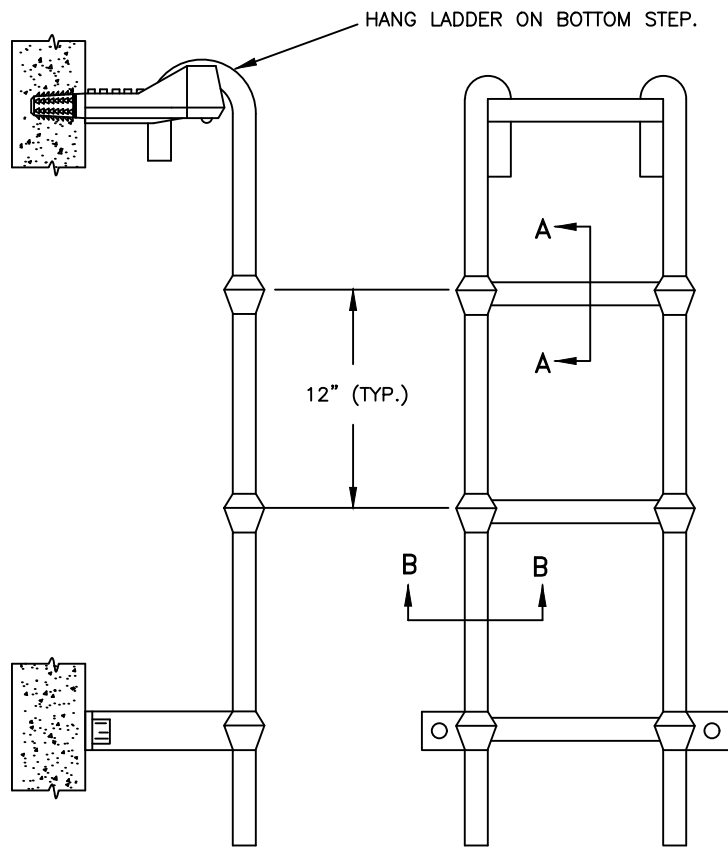

HANGING LADDER

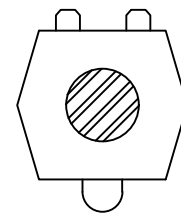

SECTION A-A

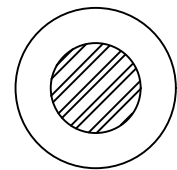

SECTION B-B

NOTES :

1. STEPS TO BE LANE INTERNATIONAL #P-14938 OR DISTRICT APPROVED EQUAL.
2. FASTEN LADDER TO MH STRUCTURE WITH STAINLESS STEEL LAG SCREWS INTO LEAD ANCHORS, OR SET LADDER BASE INTO MH SHELF PRIOR TO CURING.
3. IF REQUIRED IN NECK/ADJUSTING RINGS, HAND HOLD TO BE LANE INTERNATIONAL #HAND HOLD.

**MANHOLE STEPS AND LADDER**

NOT TO SCALE

**DETAIL APPROVALS**  
**EDITOR** TMC  
**MANAGER** SJD

**NORTHSHORE UTILITY DISTRICT**  
 2024 STANDARD SEWER DETAILS

**6**

LAST UPDATED  
 FEBRUARY 2022

**NOTES:**

1. 2"x4" SERVICE MARKER, LENGTH AS REQUIRED. PAINT PORTION OF SERVICE MARKER THAT IS ABOVE GRADE WITH WHITE PAINT. STENCIL "S/S" WITH 3" TALL BLACK LETTERS.
2. FOR NEW SEWER MAINS, INSTALL A 6" GASKETED TEE WITH THE MAIN LINE CONSTRUCTION. FOR EXISTING SEWER MAINS, CORE DRILL AND SADDLE (ROMAC "CB" SEWER SADDLE OR EQUAL). ALL DI SEWER FITTINGS SHALL BE DOMESTIC AND "MADE IN AMERICA". SIDE SEWER STUBS INSTALLED ON DI MAINS SHALL BE DI FROM THE MAIN TO THE PVC, TWO-WAY CLEANOUT. USE A ROMAC COUPLING OR EQUAL WHEN TRANSITIONING FROM DI TO PVC, SEE STANDARD SEWER DETAIL 8a FOR TRANSITION CONNECTION.
3. INSTALL 6" PVC, TWO-WAY CLEANOUT TEST TEE AND RISER PIPE AT THE PROPERTY LINE. BRING TO GRADE AFTER FINAL SIDE SEWER INSPECTION AND BACKFILL. INSTALL SIDE SEWER CLEANOUT BOX AND COVER PER STANDARD DETAIL #9a.
4. PROVIDE DETECTOR TAPE 24" ABOVE PIPE BEDDING FOR ENTIRE LENGTH OF STUB AND UP 2"x4" SERVICE MARKER.
5. FOR DEVELOPER EXTENSION PROJECTS, EXTEND STUB UP TO 10' INTO PROPERTY; OTHERWISE, TERMINATE STUB AT PROPERTY LINE OR EDGE OF EASEMENT.
6. 6" SIDE SEWER STUB AT 2% MINIMUM SLOPE, 100% (45°) MAXIMUM SLOPE.
7. APPROVED WATERTIGHT CAP.

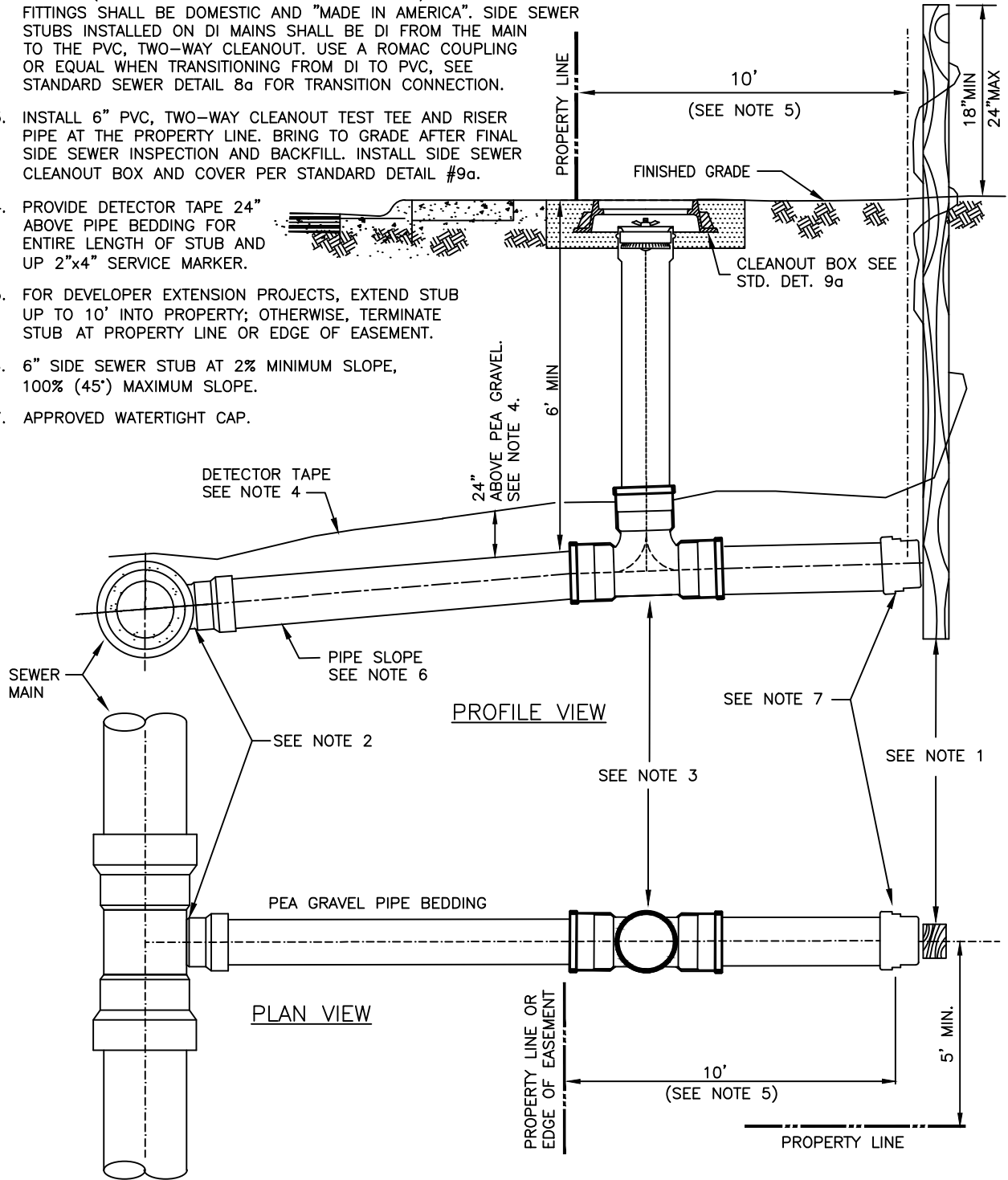

**NEW SIDE SEWER STUB  
CONNECTION TO EXISTING OR NEW MAIN**

NOT TO SCALE

**DETAIL APPROVALS**  
**EDITOR** TMC  
**MANAGER** SJD

**NORTHSHORE UTILITY DISTRICT**  
 2024 STANDARD SEWER DETAILS

**7**

LAST UPDATED  
 JANUARY 2023



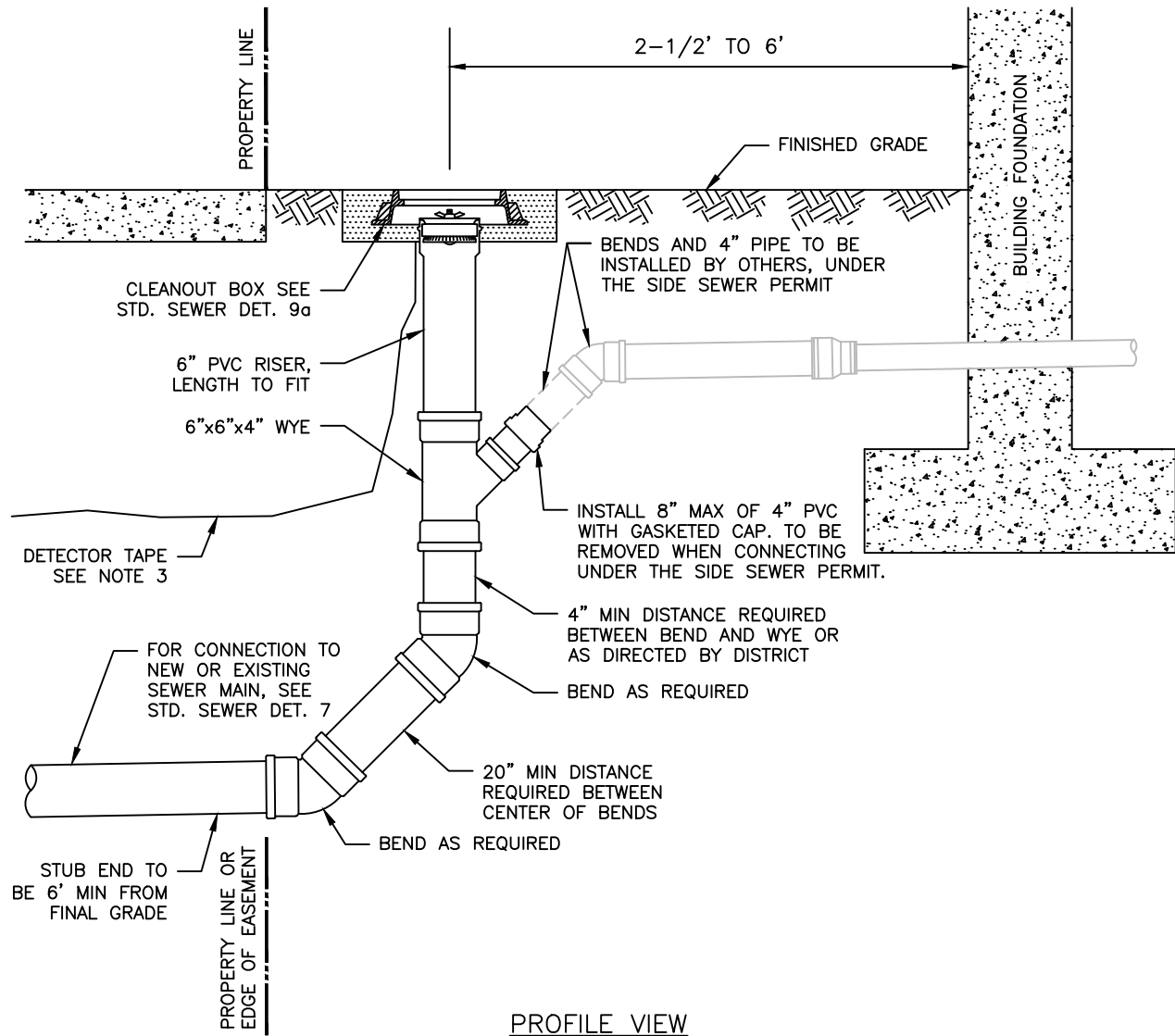

PROFILE VIEW

**NOTES:**

1. THIS SIDE SEWER CONNECTION IS ONLY ALLOWED FOR CONSTRAINED SITES AS DETERMINED BY THE DISTRICT. FOR ALL OTHER SIDE SEWER CONNECTIONS, SEE STANDARD SEWER DETAIL 7.
2. A SIDE SEWER PERMIT MUST BE OBTAINED FOR SIDE SEWER CONNECTION FROM WYE TO BUILDING FOUNDATION.
3. PROVIDE DETECTOR TAPE 24" ABOVE PIPE BEDDING FOR ENTIRE LENGTH OF STUB AND INTO THE CLEANOUT BOX.
4. PIPE BEDDING TO BE PEA GRAVEL PER STANDARD SEWER DETAIL 11.
5. ALL PIPE TO BE AT 2% MINIMUM SLOPE.

**SIDE SEWER STUB CONNECTION  
FOR CONSTRAINED SITES**

NOT TO SCALE

<b>DETAIL APPROVALS</b>	
<b>EDITOR</b>	TMC
<b>MANAGER</b>	SJD

**NORTHSHORE UTILITY DISTRICT**  
2024 STANDARD SEWER DETAILS



LAST UPDATED  
JANUARY 2023

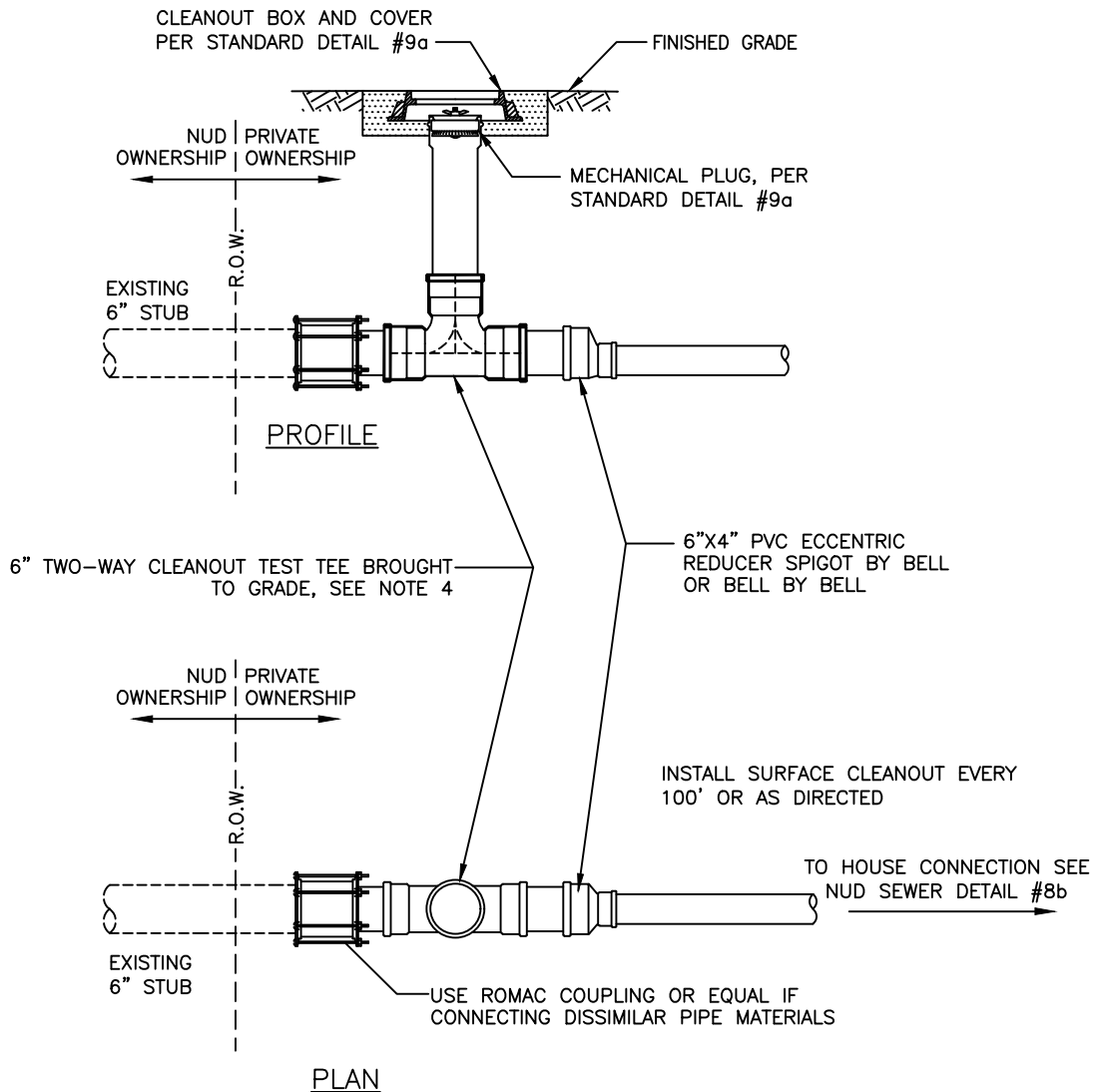

**NOTES:**

1. ALL NEW SIDE SEWER PIPE SHALL BE GASKETED PVC PIPE, SDR 35, ASTM 3034.
2. THERE SHALL BE A MINIMUM 2' OF SEPARATION BETWEEN BENDS.
3. EXISTING SIDE SEWER STUBS ON DEVELOPER EXTENSION PROJECTS MAY HAVE BEEN INSTALLED 5'-10' ONTO THE PROPERTY, AND MAY HAVE INCLUDED THE 2-WAY CLEANOUT, RISER PIPE & BOX. CONTRACTORS ARE TO CONFIRM REQUIREMENTS PRIOR TO CONSTRUCTION.
4. INSTALL 6" PVC, TWO-WAY CLEANOUT TEST TEE, AS INDICATED ABOVE. BRING TO GRADE AFTER FINAL SIDE SEWER INSPECTION AND BACKFILL. INSTALL SIDE SEWER CLEANOUT BOX AND COVER PER STANDARD DETAIL #9a.

**SIDE SEWER  
CONNECTION TO EXISTING STUB**

NOT TO SCALE

**DETAIL APPROVALS**  
**EDITOR** TMC  
**MANAGER** SJD

**NORTHSHORE UTILITY DISTRICT**  
 2024 STANDARD SEWER DETAILS

**8a**

LAST UPDATED  
 JANUARY 2023

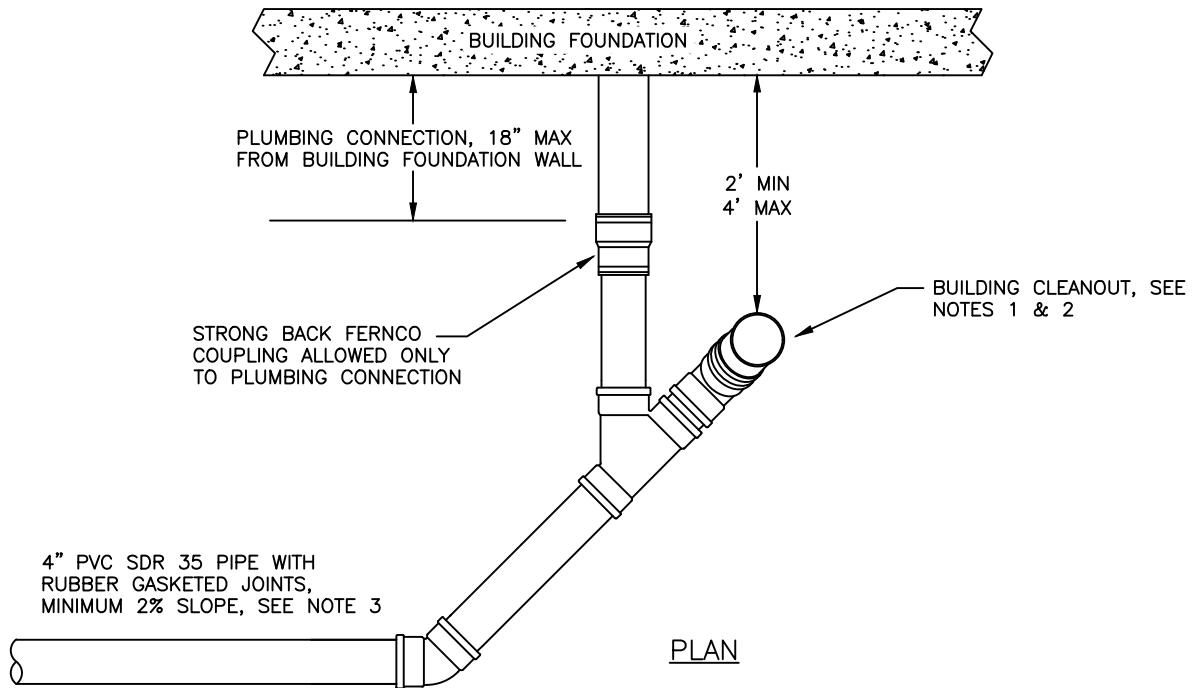

**NOTES:**

1. CLEANOUTS IN HARDSCAPE (SUCH AS SIDEWALKS, DRIVEWAYS, AND PATIOS) SHALL BE BROUGHT TO GRADE AND INSTALLED IN A CLEANOUT BOX AND PLUGGED WATERTIGHT WITH A MECHANICAL PLUG, PER STANDARD SEWER DETAIL #9a.
2. FOR CLEANOUTS BROUGHT TO SURFACE NOT IN HARDSCAPE AREAS, THE CLEANOUT CAN BE BROUGHT TO GRADE AND INSTALLED IN A LANDSCAPE/IRRIGATION BOX AND PLUGGED WATERTIGHT WITH A MECHANICAL PLUG, PER STANDARD SEWER DETAIL #9a. OTHERWISE, CLEANOUTS SHALL BE BROUGHT TO WITHIN 24" OF GRADE AND PLUGGED WATERTIGHT WITH A GASKETED CAP OR PUSH PLUG.
3. ALL PIPE MATERIAL SHALL BE BELL & SPIGOT TYPE WITH RUBBER GASKET JOINT AND SHALL BE IN CONFORMANCE WITH ASTM D3034 (SDR-35).

**SIDE SEWER  
HOUSE CONNECTION**

NOT TO SCALE

**DETAIL APPROVALS**  
**EDITOR** TMC  
**MANAGER** SJD

**NORTHSHORE UTILITY DISTRICT**  
 2024 STANDARD SEWER DETAILS



LAST UPDATED  
 JANUARY 2023

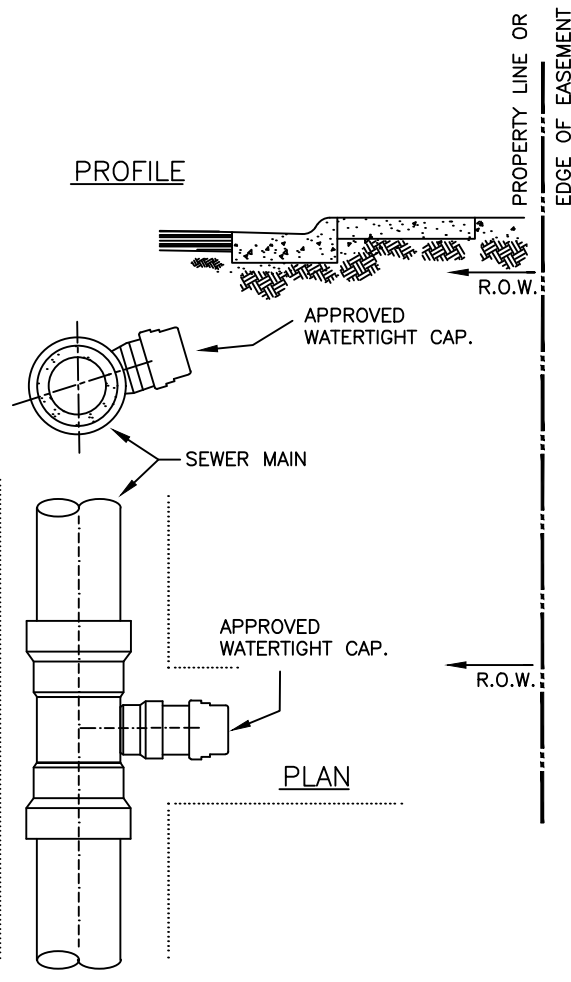

PERMANENT ABANDONMENT

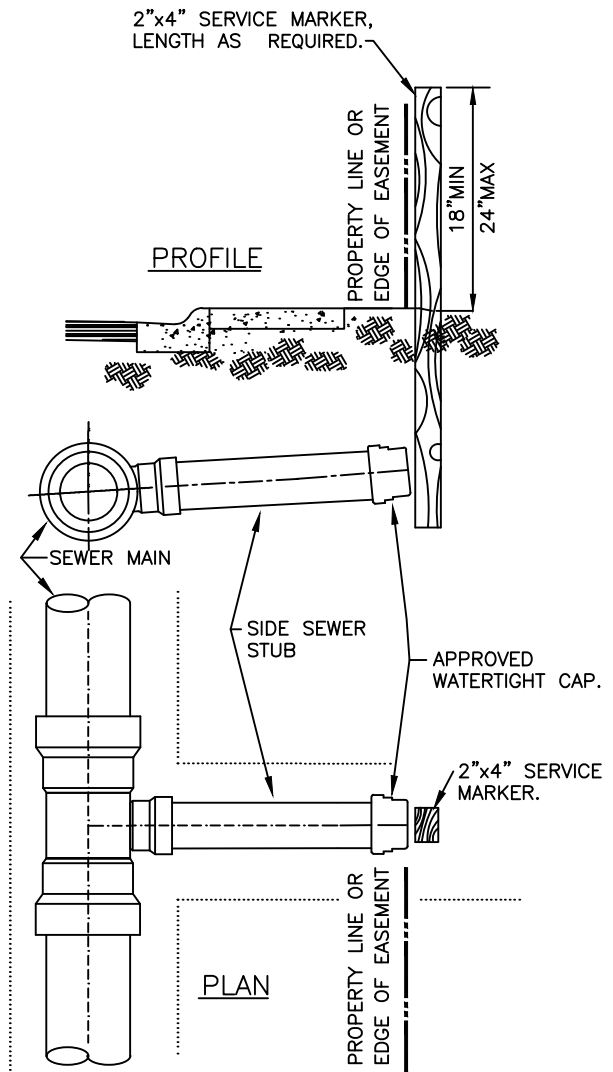

TEMPORARY ABANDONMENT

NOTES:

1. SIDE SEWERS THAT WILL NOT BE REUSED SHALL BE ABANDONED PERMANENTLY AT THE MAIN AND CAPPED WITH AN APPROVED WATERTIGHT, GASKETED CAP.
2. ALTERNATIVELY, THE SIDE SEWER CAN BE PERMANENTLY ABANDONED UTILIZING A CURED IN-PLACE PIPE (CIPP) SPOT REPAIR SLEEVE INSTALLED BY DISTRICT CREWS, AT PROPERTY OWNER'S EXPENSE. CONTACT NUD PERMIT DESK AT (425) 398-4401 FOR COST AND AVAILABILITY.
3. SIDE SEWERS THAT WILL BE REUSED SHALL BE ABANDONED TEMPORARILY WITH AN APPROVED WATERTIGHT, GASKETED CAP AT THE END OF THE 6" STUB AT THE PROPERTY LINE. INSTALL A 2"x4" MARKER AT THE END OF THE STUB.
4. PAINT PORTION OF SERVICE MARKER THAT IS ABOVE GRADE WITH WHITE PAINT. STENCIL "S/S" WITH 3" TALL BLACK LETTERS.

**SIDE SEWER CAPPING**

NOT TO SCALE

**DETAIL APPROVALS**  
**EDITOR** TMC  
**MANAGER** SJD

**NORTHSHORE UTILITY DISTRICT**  
 2024 STANDARD SEWER DETAILS



LAST UPDATED  
APRIL 2021

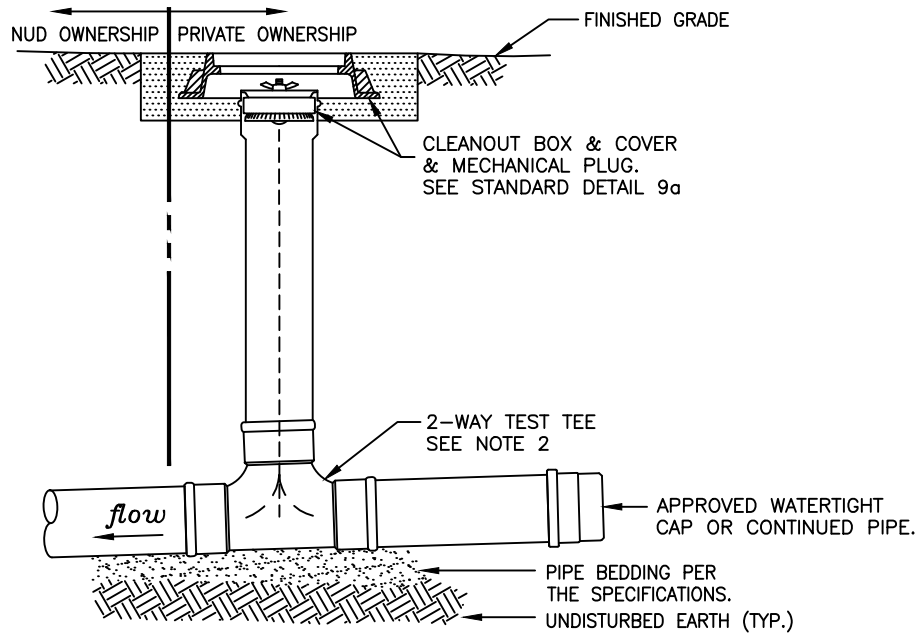

2-WAY TEST TEE (EDGE OF PROPERTY) PROFILE

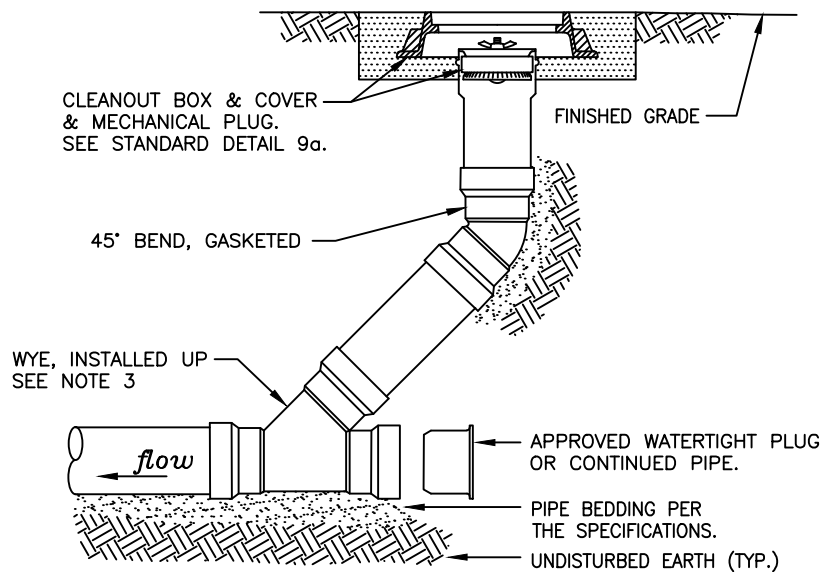

WYE CLEANOUT (INSIDE PROPERTY) PROFILE

**NOTES:**

1. SURFACE CLEANOUTS ARE REQUIRED AT THE R.O.W., CLEANOUTS LOCATED IN HARDSCAPE (SUCH AS SIDEWALKS, DRIVEWAYS, AND PATIOS), AND EVERY 100 FEET. THE SIDE SEWER CONNECTION AT THE MAIN LINE STUB SHALL BE A TWO-WAY CLEANOUT TEST TEE. SEE STANDARD DETAILS 7 & 8a.
2. A 2-WAY, DOUBLE SWEEP, TEST TEE IS REQUIRED TO BE INSTALLED AT EDGE OF EASEMENT OR EDGE OF PROPERTY LINE, SEE STANDARD DETAIL 7.
3. WYE SURFACE CLEANOUTS ARE TO BE INSTALLED EVERY 100' OR WHEN CLEANOUT IS IN HARDSCAPE WITHIN PROPERTY, SEE STANDARD DETAIL 9a. WYE IS NOT TO BE INSTALLED AT EDGE OF EASEMENT OR EDGE OF PROEPRTY LINE. ONLY EXCEPTION FOR INSTALLATION AT EDGE OF PROPERTY OR EDGE OF EASEMENT WILL BE IF WYE IS BEING INSTALLED FOR A GRINDER PUMP CONNECTION AS SHOWN ON STANDARD DETAIL 14d.
4. ALL PIPE MATERIAL SHALL BE BELL & SPIGOT TYPE WITH RUBBER GASKET JOINT AND SHALL BE IN CONFORMANCE WITH ASTM D3034 (SDR-35).

**SIDE SEWER SURFACE CLEANOUT**

NOT TO SCALE

**DETAIL APPROVALS**  
**EDITOR** TMC  
**MANAGER** SJD

**NORTHSHORE UTILITY DISTRICT**  
**2024 STANDARD SEWER DETAILS**

**9**

LAST UPDATED  
 JANUARY 2023

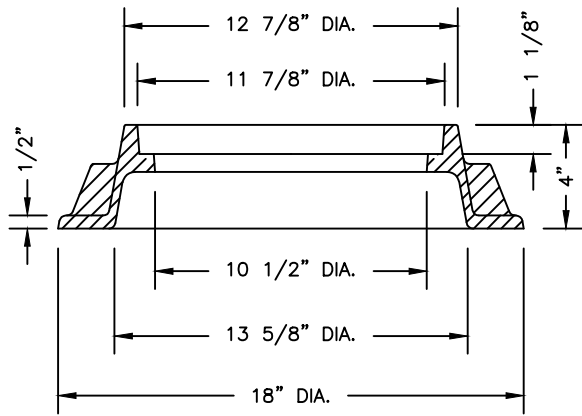

FRAME SECTION

(2) BOLT SOCKET (ALLEN HEAD)  
5/8"-11 X 1 1/2" STAINLESS STEEL  
(PART# 00981177)

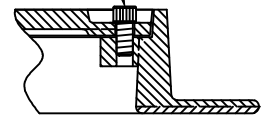

BOLTING DETAIL

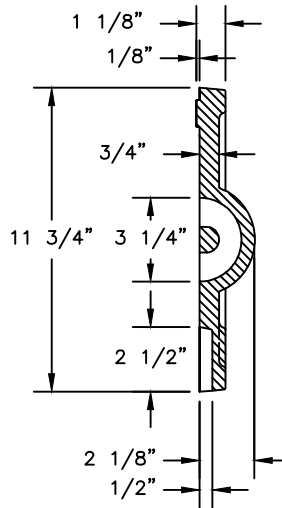

COVER SECTION

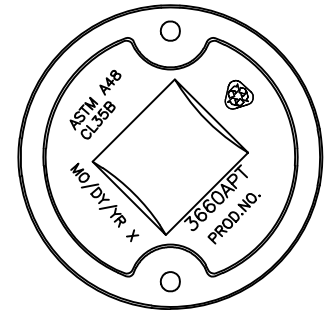

COVER BACK

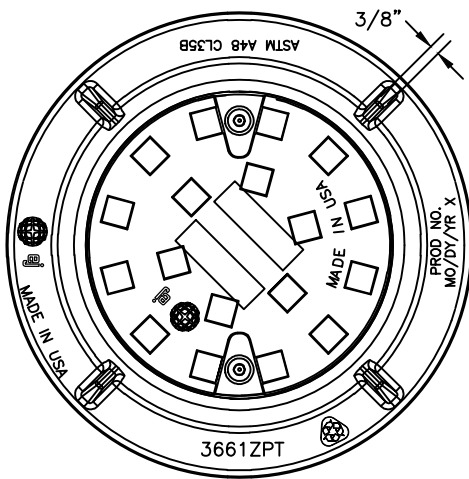

COVER AND FRAME PLAN

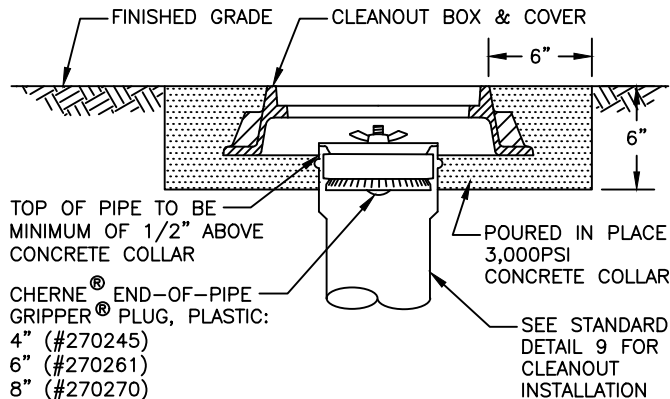

INSTALLATION PROFILE

**NOTES:**

1. SURFACE CLEANOUTS ARE REQUIRED AT THE R.O.W., THE BUILDING CONNECTION IN HARDSCAPE (SUCH AS SIDEWALKS, DRIVEWAYS, AND PATIOS), AND EVERY 100 FEET. THE SIDE SEWER CONNECTION AT THE MAIN LINE STUB SHALL BE A TWO-WAY CLEANOUT TEST TEE. SEE STANDARD DETAILS 7 & 8a.
2. CLEANOUT BOXES AND COVERS LOCATED AT PROPERTY LINE AND IN HARDSCAPES SHALL BE EAST JORDAN IRONWORKS GRAY IRON ASSEMBLY, PART #00366107, HEAVY DUTY RATED WITH STAINLESS STEEL ALLEN HEAD SOCKET BOLTS.
3. CLEANOUT BOXES AND COVERS LOCATED IN LANDSCAPE AREA'S WITHIN THE PROPERTY MAY BE A MINIMUM 6" ROUND OR 6" SQUARE LANDSCAPE/IRRIGATION BOX EQUIVALENT TO A CARSON TRUSST 708, NDS 107BC, OR NDS D1000-SG.
4. WOOD SHIMS ARE NOT ALLOWED. PLASTIC OR CONCRETE SHIMS ARE TO BE USED FOR PLACING CLEANOUT BOX WHILE CONCRETE COLLAR IS POURED.

**SURFACE CLEANOUT BOX**

NOT TO SCALE

**DETAIL APPROVALS**  
**EDITOR** TMC  
**MANAGER** EM

**NORTHSHORE UTILITY DISTRICT**  
 2024 STANDARD SEWER DETAILS



LAST UPDATED  
MARCH 2024

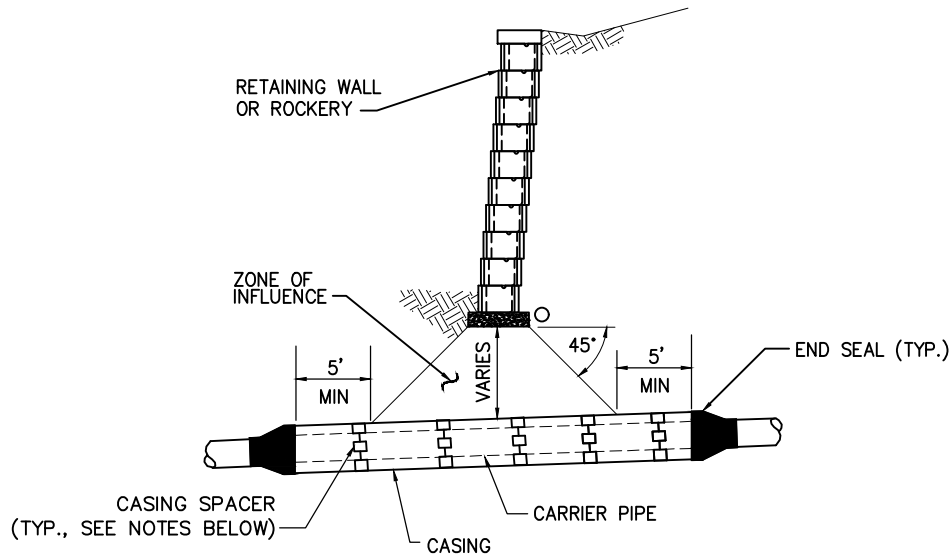

ROCKERY OR WALL SECTION

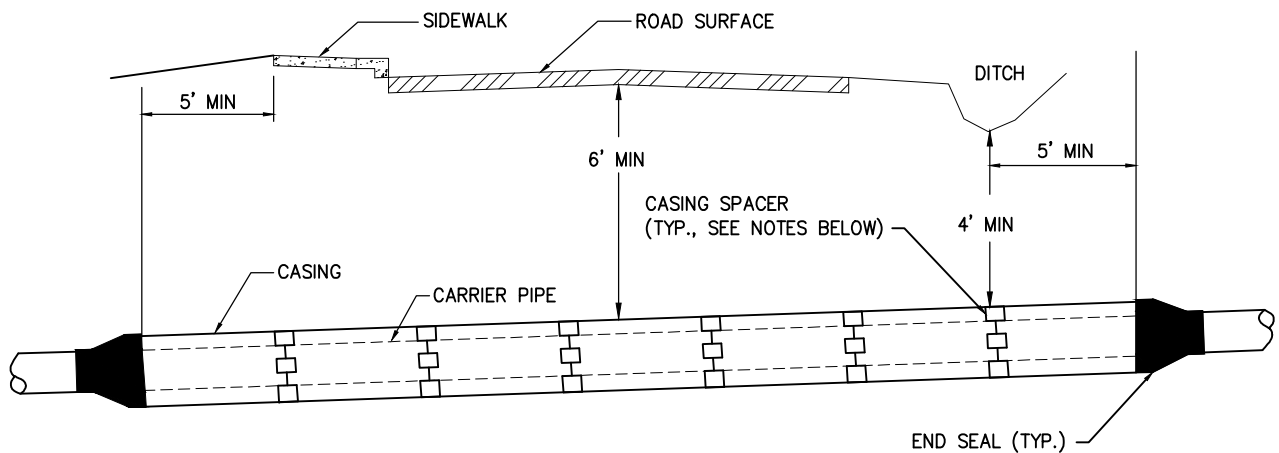

ROADWAY SECTION

NOTES:

1. CASING LENGTH, TYPE, LOCATION AND SIZE SHALL BE AS SHOWN ON THE PLANS OR AS DIRECTED BY THE DISTRICT AND SHALL BE IN ACCORDANCE WITH THE SPECIFICATIONS.
2. CASING SPACERS SHALL INCLUDE POLYETHYLENE RUNNERS WITH STAINLESS STEEL BANDS PER THE SPECIFICATIONS.
3. CASING SPACERS SHALL BE INSTALLED AT A MAXIMUM 10' SPACING, WITH A SPACER LOCATED BEHIND EACH PIPE BELL AND WITH SPACERS LOCATED WITHIN 2' OF CASING ENDS.
4. CARRIER PIPE SHALL BE CL 52 DUCTILE IRON RESTRAINED JOINT PIPE UNLESS OTHERWISE SPECIFIED.

**CASING PIPE**

NOT TO SCALE

**DETAIL APPROVALS**

**EDITOR** *GSM*

**MANAGER** *DPK*

**NORTHSHORE UTILITY DISTRICT**

**2024 STANDARD SEWER DETAILS**

**10**

LAST UPDATED  
FEBRUARY 2014

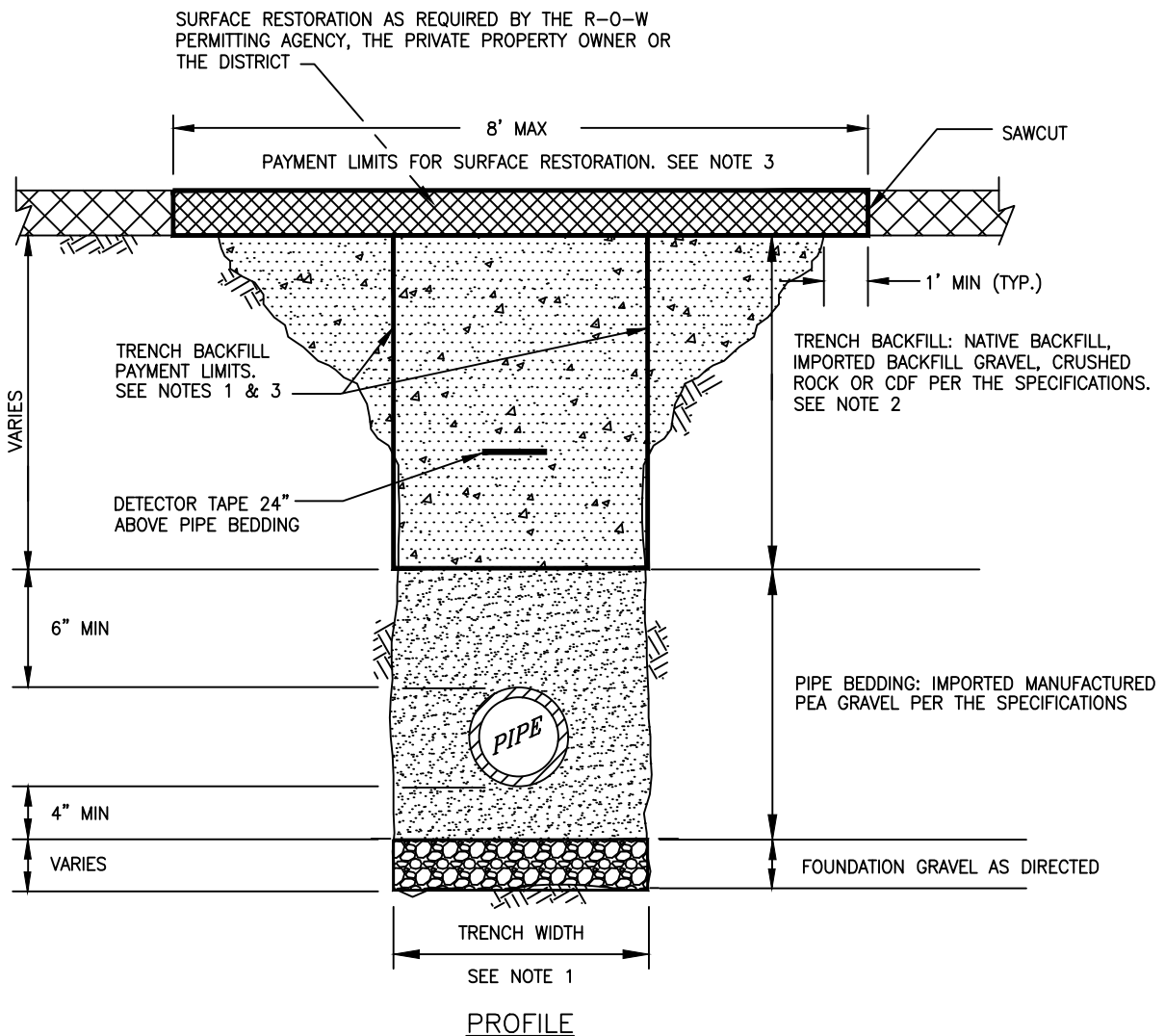

**NOTES:**

1. TRENCH WIDTH:  
 MINIMUM: PIPE O.D. + 24" (12" EACH SIDE OF PIPE).  
 MAXIMUM: 40" FOR 15"Ø PIPE AND SMALLER.  
 (1 1/2" X I.D.) + 18" FOR 18"Ø PIPE AND LARGER.  
 THE NEAT-LINE PAYMENT LIMITS FOR TRENCH BACKFILL MATERIALS SHALL BE BASED UPON THE MAXIMUM ALLOWABLE TRENCH WIDTH AS SHOWN ABOVE.
2. NATIVE MATERIAL, IF ALLOWED FOR TRENCH BACKFILL, SHALL MEET THE REQUIREMENTS OF SELECT BORROW PER THE SPECIFICATIONS. TRENCH BACKFILL SHALL BE COMPACTED TO A MINIMUM OF NINETY-FIVE PERCENT (95%) OF MODIFIED PROCTOR IN THE RIGHT-OF-WAY AND IMPROVED EASEMENTS AND TO NINETY PERCENT (90%) IN UNIMPROVED EASEMENT AREAS. SEE THE SPECIFICATIONS FOR ADDITIONAL INFORMATION.
3. THE NEAT-LINE LIMITS SHOWN WILL BE USED TO CALCULATE THE MAXIMUM QUANTITY OF TRENCH BACKFILL AND SURFACE RESTORATION MATERIALS ALLOWED. PAYMENT FOR BEDDING GRAVEL WILL BE CONSIDERED INCIDENTAL TO PAYMENT MADE FOR PIPE. PAYMENT FOR FOUNDATION ROCK WILL BE BASED UPON THE QUANTITIES USED AS DIRECTED BY THE DISTRICT. SEE THE CONTRACT DOCUMENTS FOR ADDITIONAL INFORMATION.
4. RECYCLED CONCRETE WILL NOT BE ALLOWED AS PIPE BEDDING OR TRENCH BACKFILL FOR DI PIPE.
5. ALL DUCTILE IRON PIPE REQUIRES POLYETHYLENE ENCASEMENT. SEE THE DISTRICTS MATERIALS OF CONSTRUCTION SPECIFICATIONS FOR ADDITIONAL INFORMATION.

**TYPICAL TRENCH SECTION & PAYMENT LIMITS**

NOT TO SCALE

**DETAIL APPROVALS**  
**EDITOR** TMC  
**MANAGER** SJD

**NORTHSHORE UTILITY DISTRICT**  
 2024 STANDARD SEWER DETAILS

**11**

LAST UPDATED  
 JANUARY 2023



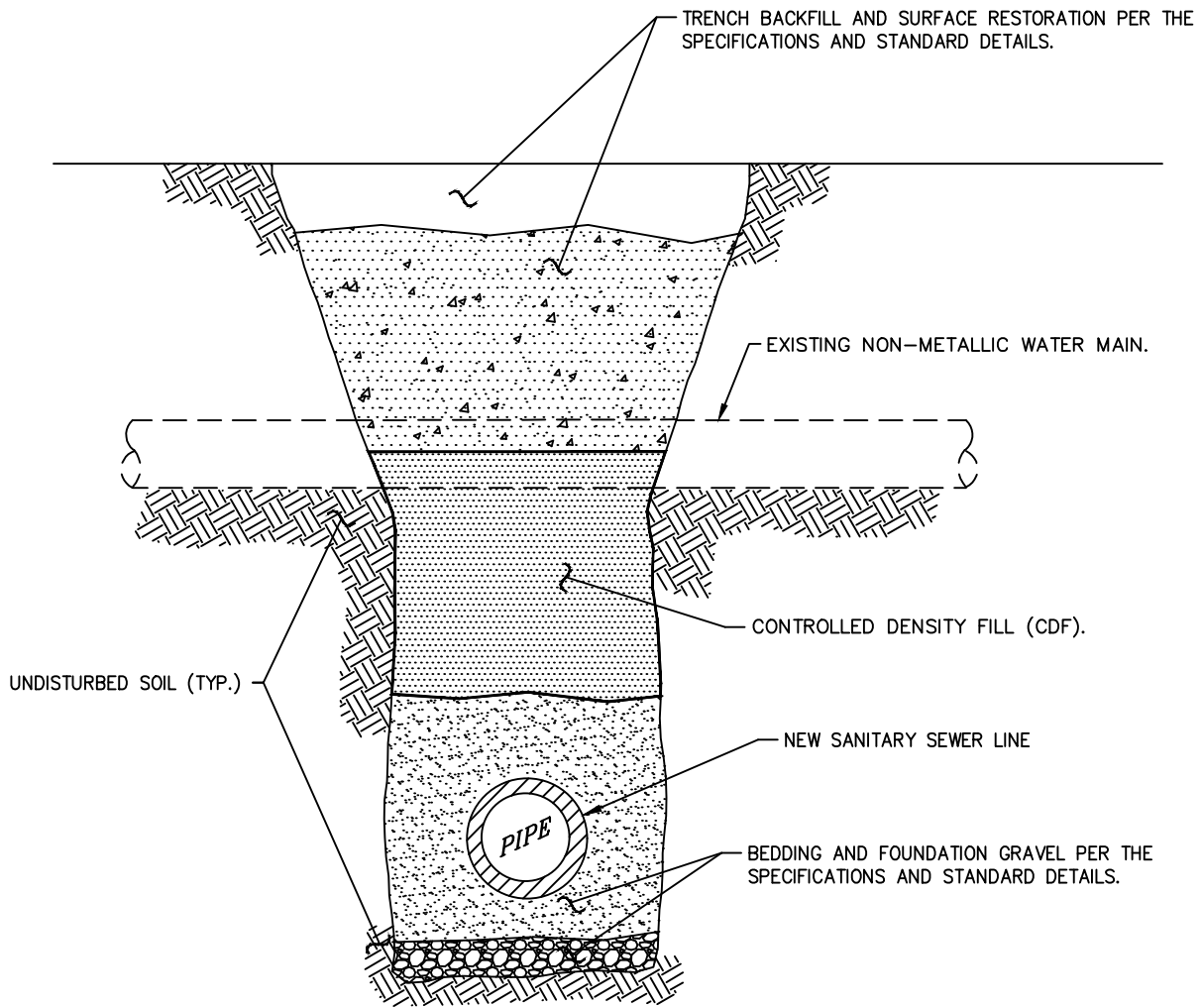

PROFILE

NOTES:

1. WHERE UTILITY LINES CROSS UNDER EXISTING NON-METALLIC WATER MAIN SUCH AS ASBESTOS CEMENT, PERMASTRAN, OR CLASS 200 PVC, BACKFILL WITH CONTROLLED DENSITY FILL (CDF) BETWEEN THE BEDDING MATERIAL AND THE SPRING LINE (MID-POINT) OF THE NON-METALLIC PIPE. TRENCH BACKFILL CAN THEN BE USED ABOVE THE CDF TO THE FINAL GRADE.
2. IF NON-METALLIC PIPE MUST BE REMOVED, AS DETERMINED BY THE DISTRICT, REPLACE WITH CL. 52 DUCTILE IRON PIPE, SIZED TO MATCH. D.I. PIPE TO EXTEND A MINIMUM OF 18" INTO UNDISTURBED SOIL (ALL APPLICABLE ENVIRONMENTAL PROTECTION AGENCY, PUGET SOUND AIR POLLUTION CONTROL AGENCY, AND LABOR AND INDUSTRY REQUIREMENTS AND REGULATIONS SHALL BE MET IN CUTTING, HANDLING OR DISPOSING OF ASBESTOS CEMENT PIPE).

**NON-METALLIC PIPE CROSSING**

NOT TO SCALE

**DETAIL APPROVALS**  
**EDITOR** TDC  
**MANAGER** DPK

**NORTHSHORE UTILITY DISTRICT**  
**2024 STANDARD SEWER DETAILS**

**12**

LAST UPDATED  
 JULY 2018

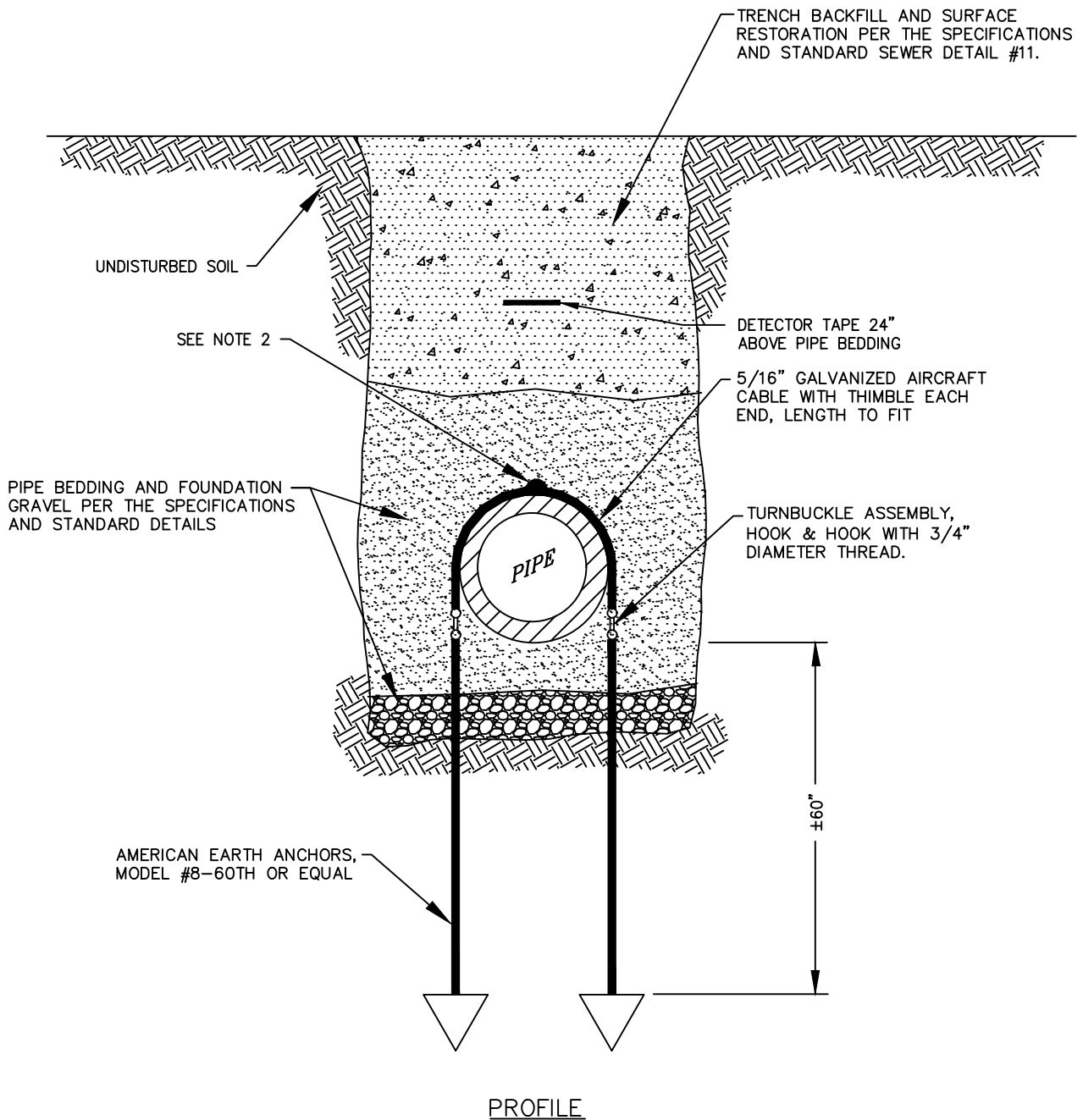

**NOTES:**

1. PIPE ANCHORS SHALL BE INSTALLED ON ALL SLOPES GREATER THAN 20% WITH SPACING AS FOLLOWS:
  - A. NOT GREATER THAN 36 FT. ON GRADES FROM 20% TO 35%.
  - B. NOT GREATER THAN 24 FT. ON GRADES FROM 35% TO 50%.
  - C. NOT GREATER THAN 16 FT. ON GRADES GREATER THAN 50%.
2. IF CARRIER PIPE IS INSTALLED IN CASING PIPE, INSTALL FLANGE OR BRACKET TO SECURE PIPE ANCHOR TO CASING PIPE.

**PIPE ANCHOR**

NOT TO SCALE

**DETAIL APPROVALS**  
**EDITOR** TMC  
**MANAGER** SJD

**NORTHSHORE UTILITY DISTRICT**  
 2024 STANDARD SEWER DETAILS

**13**

LAST UPDATED  
 FEBRUARY 2020

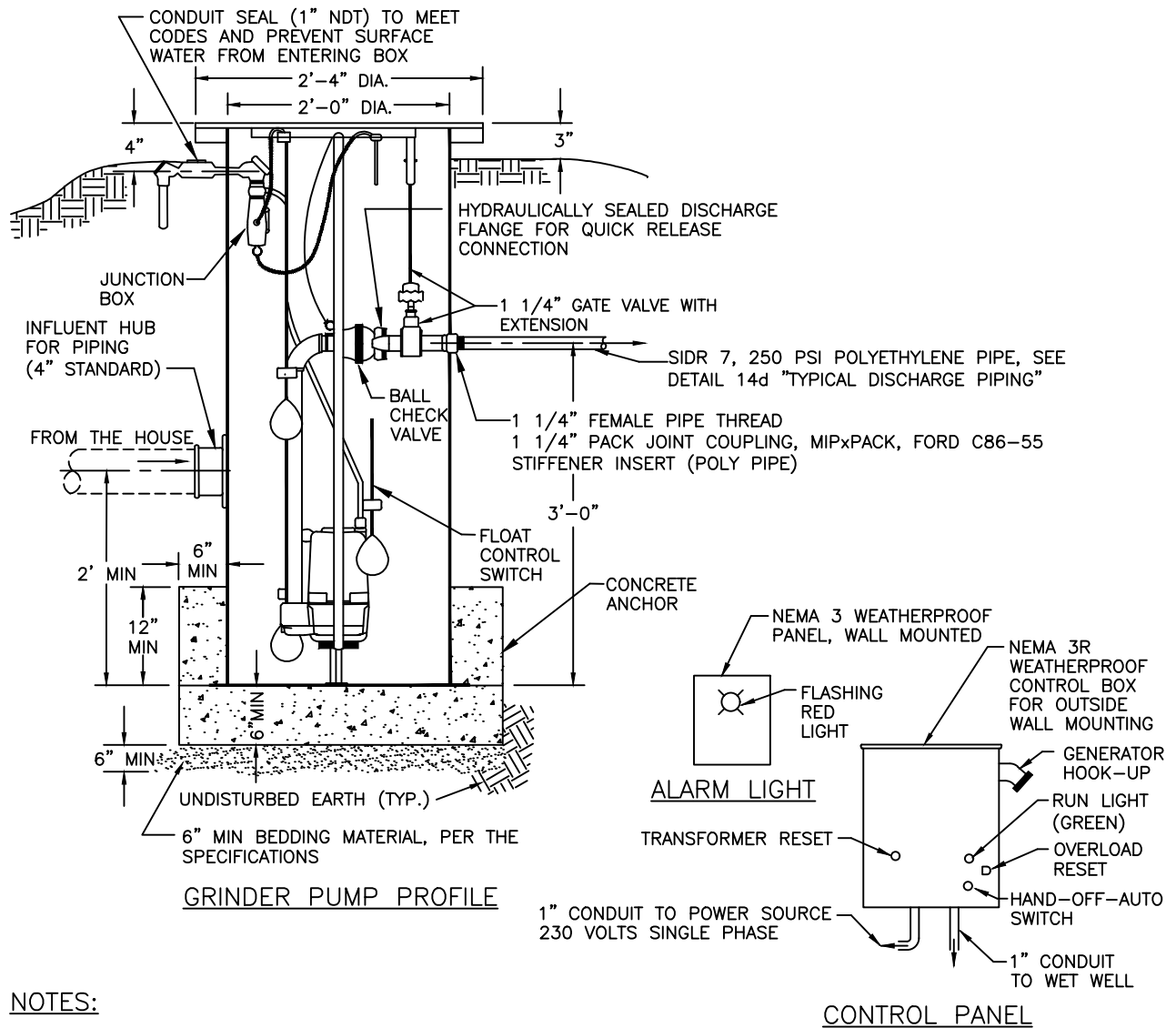

**NOTES:**

HYDROMATIC HPG-200 COMPLETE PACKAGED SEWER GRINDER LIFT STATION (EQUAL TO THE TG-PRO SYSTEM) TO INCLUDE THE FOLLOWING:

1. GRINDER PUMP WITH 2HP SUBMERSIBLE SINGLE PHASE MOTOR (ADEQUATE FOR SINGLE RESIDENCE UP TO 100' HEAD AT 5" IMPELLER DIA.)
2. TWO SEALED FLOAT TYPE MERCURY SWITCHES FOR LEVEL CONTROL
3. ONE FLOAT SWITCH FOR ALARM CONTROL
4. 1" NPT MALE CONDUIT OUTSIDE OF SUMP FOR CONTROL WIRING
5. DISCHARGE PIPING SHALL INCLUDE A CHECK VALVE, A GATE VALVE AND NPT FEMALE CONNECTION OUTSIDE OF SUMP (DIA. PER PRESSURE PIPE DIA.)
6. INFLUENT PIPING SHALL PROVIDE HUB FOR PVC PIPE OUTSIDE OF SUMP (DIA. PER SEWERS DIA.)
7. FIBERGLASS SUMP BASIN 24" I.D. x 5'-0" HIGH (PER BULLETIN SPG-604 (HYDROMATIC OR EQUAL))
8. NEMA 3R LOCKING CONTROL PANEL WITH GENERATOR HOOK-UP, MOUNTED OUTSIDE ON HOUSE WALL
9. RED ALARM LIGHT PANEL, MOUNTED OUTSIDE ON HOUSE WALL
10. SEE ADDITIONAL INFORMATION PER STANDARD SEWER DETAIL 14d GENERAL NOTES

**SINGLE FAMILY GRINDER PUMP STATION  
HYDROMATIC**

NOT TO SCALE

**DETAIL APPROVALS**  
**EDITOR** TMC  
**MANAGER** SJD

**NORTHSHORE UTILITY DISTRICT**  
 2024 STANDARD SEWER DETAILS

**14a**

LAST UPDATED  
APRIL 2021

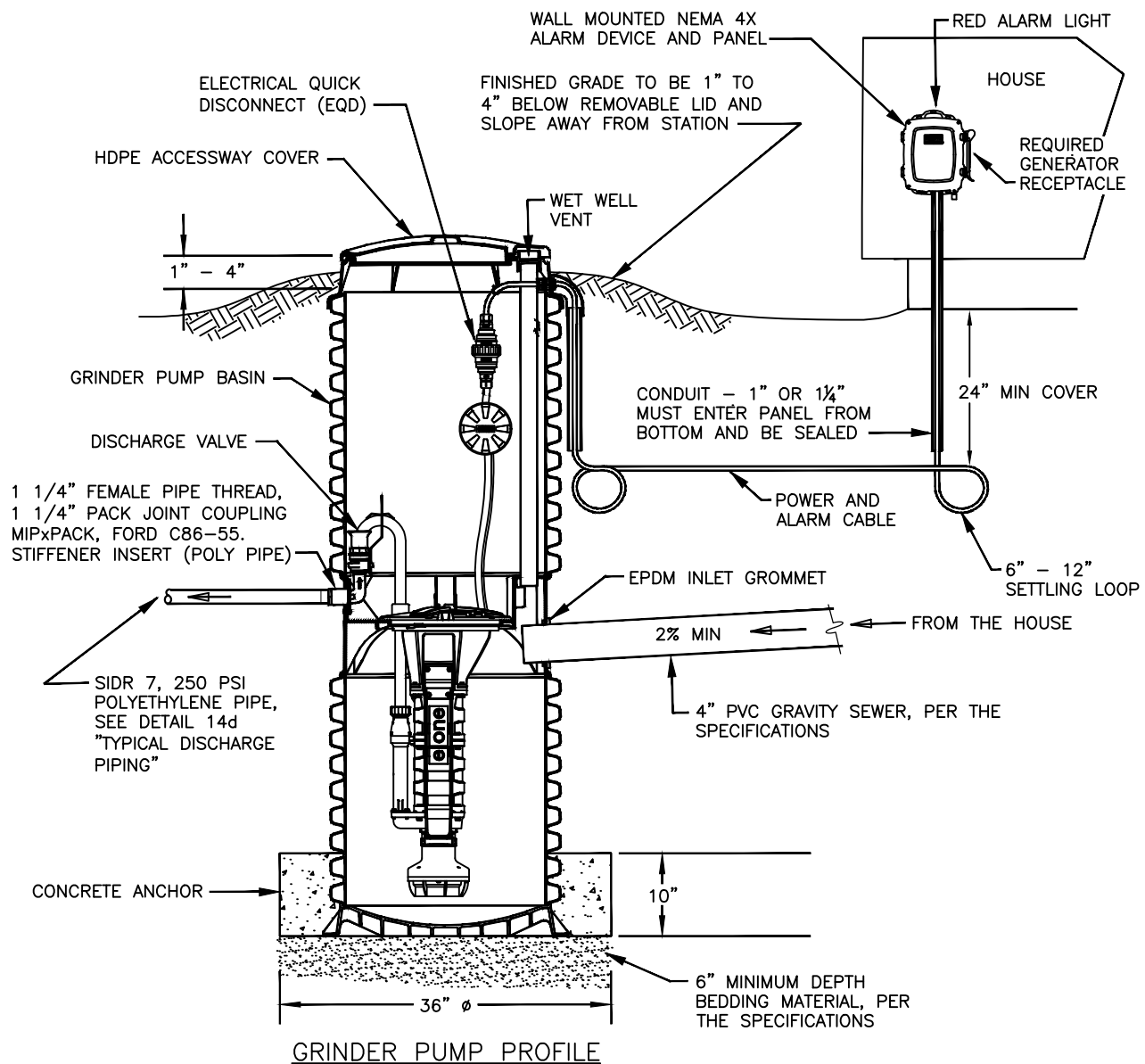

**NOTES:**

ENVIRONMENTAL ONE (E-ONE) DH071 COMPLETE PACKAGED SEWAGE GRINDER PUMP STATION TO INCLUDE THE FOLLOWING:

1. ONE SIMPLEX GRINDER PUMP WITH 70 GAL CAPACITY AND HDPE BASIN (ADEQUATE FOR SINGLE RESIDENCE)
2. ASSEMBLED IN THE BASIN - NEMA 6P ELECTRICAL QUICK DISCONNECT, PUMP REMOVAL SYSTEM, STAINLESS STEEL DISCHARGE ASSEMBLY/SHUT-OFF VALVE, AND ANTI-SIPHON VALVE/CHECK VALVE
3. NEMA 4X ALARM PANEL EQUIPPED WITH CIRCUIT BREAKERS AND NECESSARY INTERNAL WIRING CONTROLS
4. DISCHARGE PIPING SHALL INCLUDE FEMALE PIPE THREAD FOR PRESSURE PIPE CONNECTION (DIA. PER PRESSURE PIPE DIA, 1 1/4" MIN)
5. INFLUENT PIPING SHALL PROVIDE INLET GROMMET FOR SDR 35 PVC PIPE (DIA. PER SEWESIDE DIA.)
6. ALARM PANEL, INCLUDING RED ALARM LIGHT AND GENERATOR RECEPTACLE, MOUNTED OUTSIDE ON HOUSE WALL
7. SEE ADDITIONAL INFORMATION PER STANDARD SEWER DETAIL 14d GENERAL NOTES

**SINGLE FAMILY GRINDER PUMP STATION  
E-ONE**

NOT TO SCALE

**DETAIL APPROVALS**  
**EDITOR** TMC  
**MANAGER** SJD

**NORTHSHORE UTILITY DISTRICT**  
 2024 STANDARD SEWER DETAILS

**14b**  
 LAST UPDATED  
 APRIL 2021

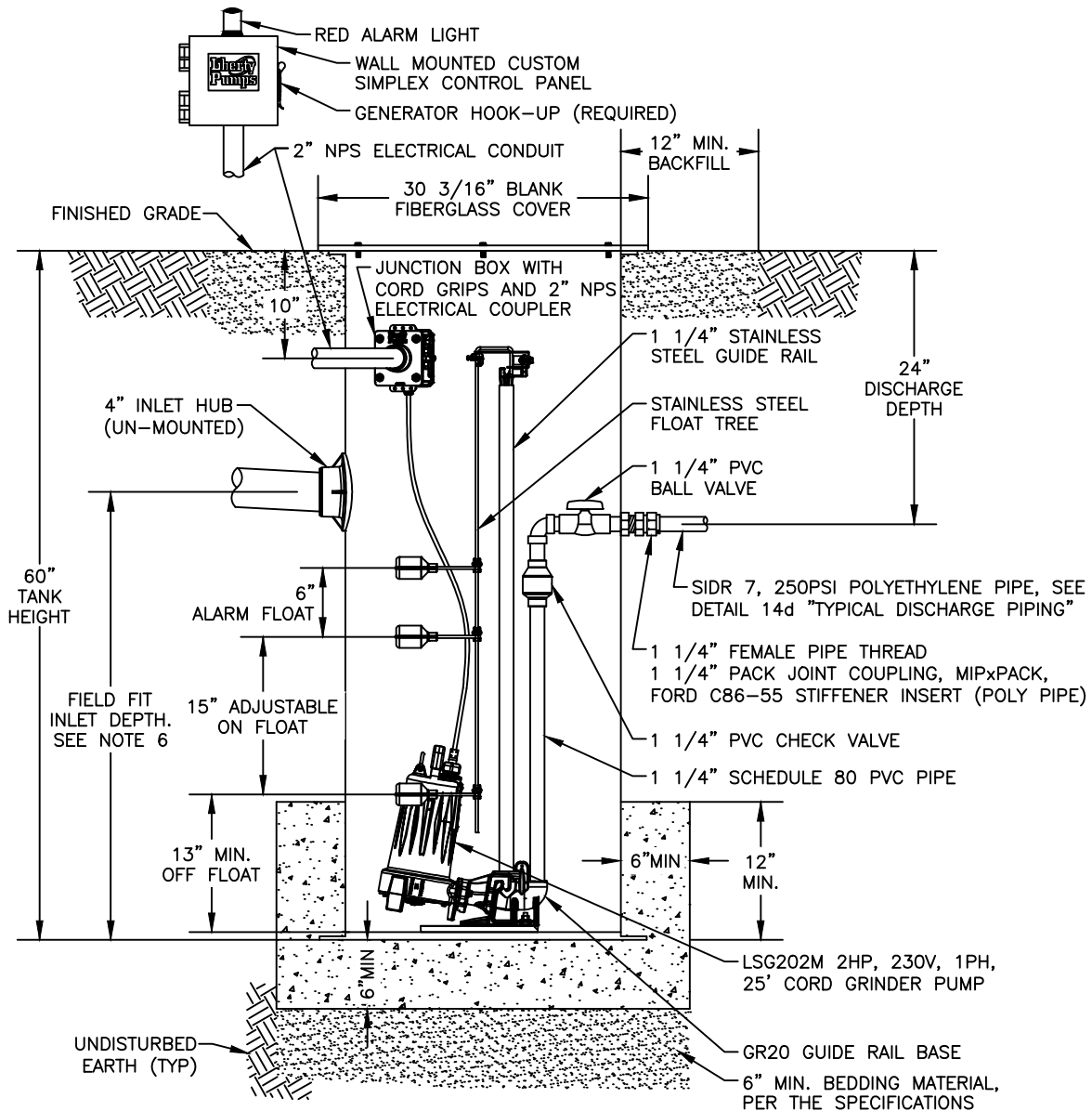

**NOTES:**

**GRINDER PUMP PROFILE**

LIBERTY PUMP EPS91174 COMPLETE PACKAGED SEWAGE GRINDER PUMP STATION TO INCLUDE THE FOLLOWING:

1. 2HP LSG-SERIES GRINDER PUMP, 208-230V, SINGLE PHASE (ADEQUATE FOR SINGLE RESIDENCE, UP TO 108' TOTAL DYNAMIC HEAD).
2. THREE FLOAT TYPE MECHANICAL PILOT DUTY SWITCHES TO CONTROL PUMP AND HIGH LEVEL ALARM.
3. JUNCTION BOX AND 2" CONDUIT BULKHEAD.
4. PVC DISCHARGE PIPING SHALL INCLUDE CHECK VALVE, BALL VALVE, AND 1 1/4" DISCHARGE BULKHEAD.
5. FIBERGLASS TANK WITH ANTI-FLOTATION FLANGE. 24" ID x 60" HIGH.
6. 4" INLET HUB, UN-MOUNTED TO BE INSTALLED AT CORRECT DEPTH IN FIELD PER MANUFACTURER'S RECOMMENDATIONS.
7. SIMPLEX CONTROL PANEL, NEMA 4X ENCLOSURE, WITH GENERATOR RECEPTACLE. INCLUDES HIGH LEVEL ALARM AND TOP RED BEACON. ENCLOSURE MOUNTED OUTSIDE ON HOUSE WALL
8. SEE ADDITIONAL INFORMATION PER STANDARD SEWER DETAIL 14d GENERAL NOTES

**SINGLE FAMILY GRINDER PUMP STATION  
LIBERTY PUMPS**

NOT TO SCALE

**DETAIL APPROVALS**  
**EDITOR** TMC  
**MANAGER** SJD

**NORTHSHORE UTILITY DISTRICT**  
 2024 STANDARD SEWER DETAILS

**14c**

LAST UPDATED  
APRIL 2021

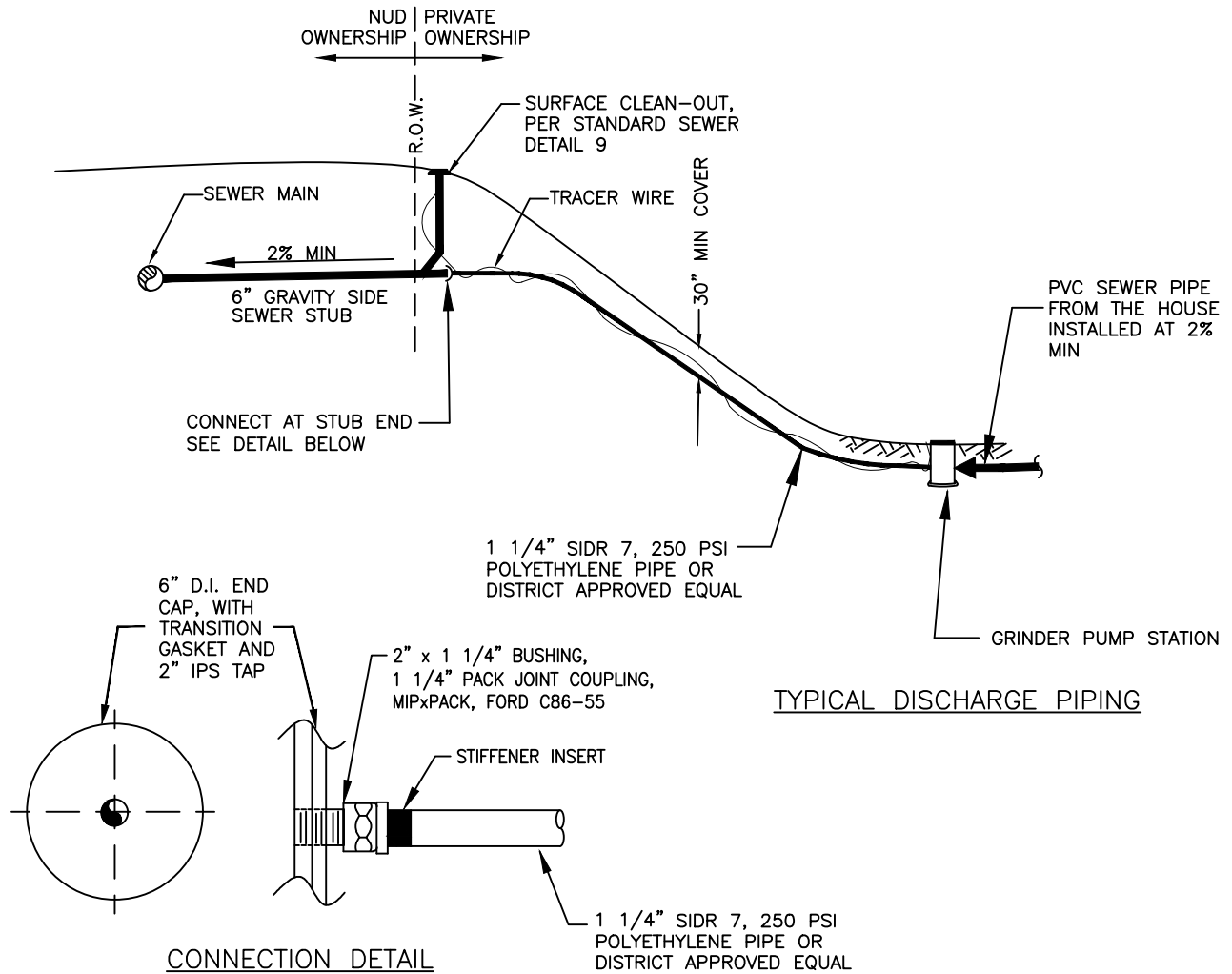

CONNECTION DETAIL

**NOTES:**

1. THE MINIMUM REQUIREMENTS FOR A RESIDENTIAL SEWAGE PUMPING SYSTEM CONNECTING A SINGLE RESIDENCE TO THE DISTRICT'S SYSTEM ARE SPECIFIED AS FOLLOWS. THE DISTRICT ACCEPTS NO RESPONSIBILITY FOR THE DESIGN, OPERATION AND MAINTENANCE OF SUCH PRIVATELY OWNED AND OPERATED SYSTEMS. INSTALLATION OF GRINDER PUMP SYSTEMS MUST BE PREAPPROVED BY THE DISTRICT.
2. ALL EQUIPMENT AND ACCESSORIES SHALL BE STANDARD MANUFACTURED ITEMS AND THOSE COMING IN DIRECT CONTACT WITH SEWAGE SHALL BE SPECIFICALLY MANUFACTURED FOR SEWAGE USE.
3. LIFT STATION MUST BE LOCATED OUTSIDE THE BUILDING. IF THE STATION IS COMPLETELY BURIED, INSTALL 48" I.D. MANHOLE WITH FRAME AND COVER OVER STATION FOR ACCESS.
4. THE PUMP SHALL BE E-ONE DH071, HYDRAMATIC HPG-200 OR LIBERTY PUMPS EPS91174, AS SPECIFIED HEREIN. NO OTHER PUMP TYPES SHALL BE PERMISSIBLE.
5. A 14 GAUGE TRACER WIRE, CONTINUOUS POLYETHYLENE INSULATED COPPER, SHALL BE WRAPPED AROUND THE ENTIRE COURSE OF THE POLY PRESSURE PIPE AND BROUGHT TO THE SURFACE IN THE CLEAN-OUT BOX AND AT THE STATION.
6. POLY PRESSURE PIPE TO BE 1 1/4" MIN. SIDR 7, 250 PSI POLYETHYLENE PIPE, OR DISTRICT APPROVED EQUAL.
7. POLY PRESSURE PIPE TO BE INSTALLED AT A CONTINUOUS UPHILL GRADE WITH NO JOINTS OR COUPLINGS IF PIPE RUN IS UNDER 300 FEET.
8. DETECTOR TAPE REQUIRED 1'-0" ABOVE PIPING WHEN POLY PRESSURE PIPE CROSSES OTHER PROPERTIES OR IS LOCATED ALONG COMMON ACCESS ROADS.
9. EVERY INSTALLATION SHALL BE EQUIPPED WITH AN ALARM PANEL, INCLUDING RED ALARM LIGHT AND GENERATOR RECEPTACLE, MOUNTED OUTSIDE ON HOUSE WALL.

**SINGLE FAMILY GRINDER PUMP STATION  
DISCHARGE PIPING/GENERAL NOTES**

NOT TO SCALE

**DETAIL APPROVALS**  
**EDITOR** TMC  
**MANAGER** SJD

**NORTHSHORE UTILITY DISTRICT**  
 2024 STANDARD SEWER DETAILS



LAST UPDATED  
APRIL 2021

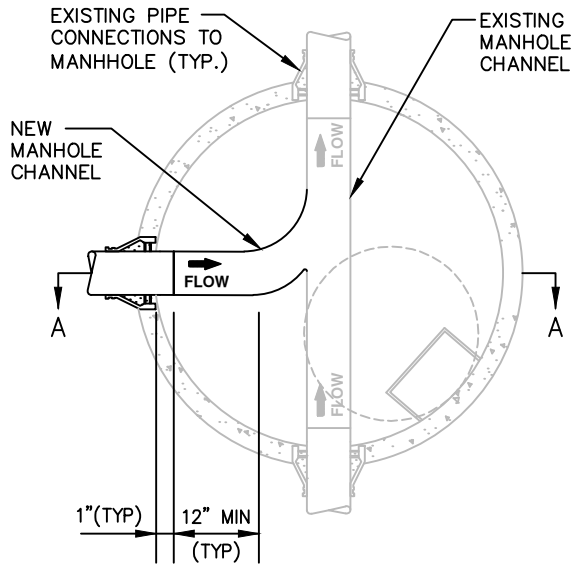

EXISTING CONCRETE BASE PLAN

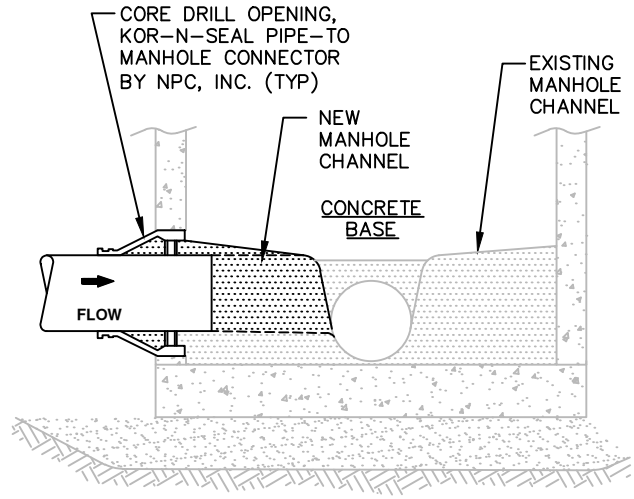

SECTION A-A

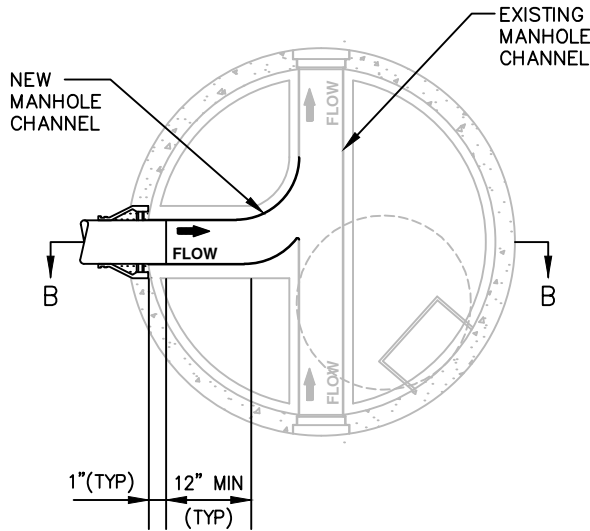

EXISTING F.R.P./P.P. LINER PLAN

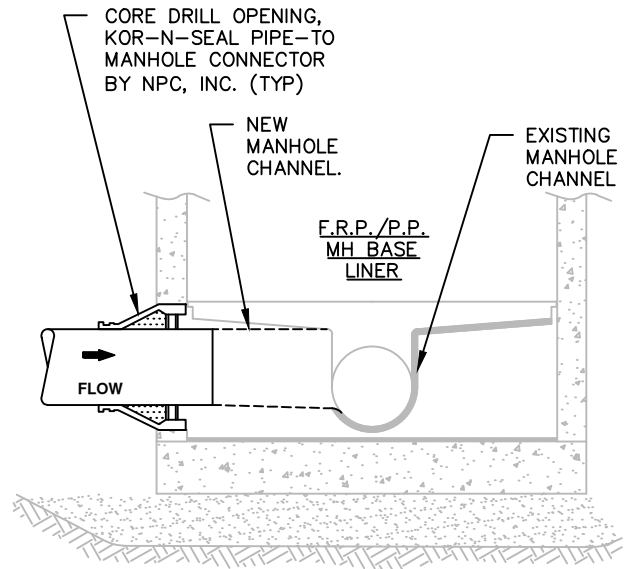

SECTION B-B

NOTES:

1. IF P.P. BASE LINER IS UTILIZED, A MINIMUM SLOPE OF 0.06' IS ACCEPTABLE ACROSS THE INVERT CHANNEL. THE F.R.P. BASE LINER SHALL REQUIRE THE DISTRICT STANDARD MINIMUM SLOPE OF 0.1' ACROSS THE INVERT CHANNEL.
2. THE NEW CHANNEL SHALL HAVE NO SHARP EDGES AND SHALL DIRECT FLOW TOWARDS EXISTING FLOW DIRECTION. NO 90° BENDS IN THE CHANNELING.
3. CONCRETE BASES SHALL BE RE-CHANNELED USING 3,000 PSI STRUCTURAL CONCRETE.
4. FIBER REINFORCED PLASTIC (F.R.P.) AND POLYPROPYLENE (P.P.) BASE LINERS SHALL BE RE-GLASSED PER MANUFACTURER'S SPECIFICATIONS. PLEASE CONTACT NORTHSORE UTILITY DISTRICT FOR REPAIR REQUIREMENTS.
5. SEE NUD SEWER DETAIL #1 FOR PRECAST CONCRETE MANHOLE, TOP SECTION, LADDER, AND STEPS.
6. CROWN OF NEW PIPE CONNECTION SHALL MATCH EXISTING CHANNEL'S CROWN OR AS APPROVED BY DISTRICT.

**NEW CONNECTION TO EXISTING MANHOLE**

NOT TO SCALE

**DETAIL APPROVALS**

**ENGINEER** TMC

**MANAGER** SJD

**NORTHSORE UTILITY DISTRICT**

**2024 STANDARD SEWER DETAILS**

**15**

LAST UPDATED  
JANUARY 2023

GROUT ADJUSTING RINGS INSIDE, OUTSIDE AND BETWEEN. GROUT UNDER CASTING. INSIDE GROUT SHALL HAVE A SMOOTH BROOM FINISH.

MANHOLE FRAME AND COVER PER THE STANDARD SEWER DETAIL #5. LOCATE AS SHOWN ON PLAN.

IN UNPAVED AREAS, OR AS SHOWN ON THE PLANS, PROVIDE AN ASPHALT OR CONCRETE RING AROUND THE MANHOLE FRAME, 12" WIDE AND 6" THICK. CONCRETE RING SHALL HAVE A BROOM/TROWEL FINISH

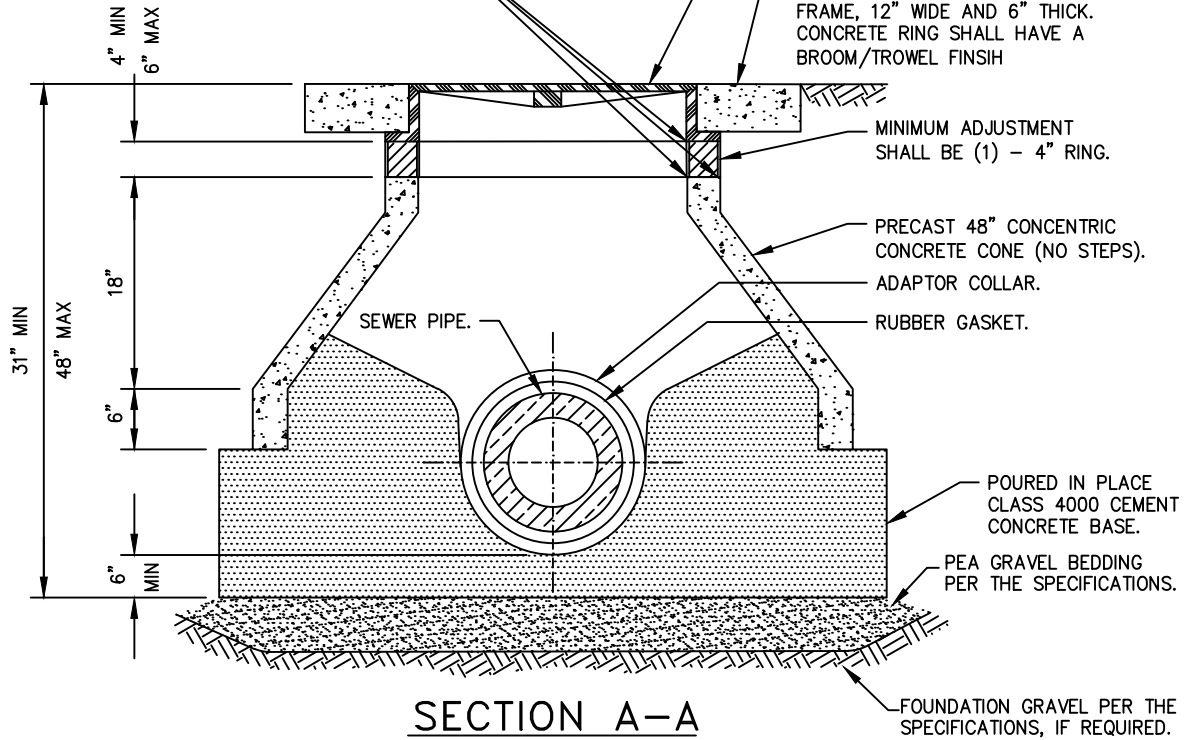

**SECTION A-A**

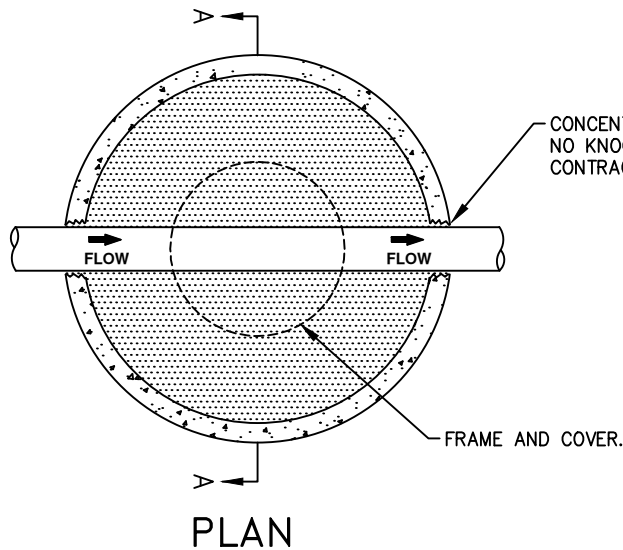

CONCENTRIC CONCRETE CONE SHALL BE SOLID WALL WITH NO KNOCK-OUTS OR KOR-N-SEAL BOOTS INSTALLED. CONTRACTOR TO NOTCH IN FIELD AS REQUIRED.

**PLAN**

**NOTES:**

1. APPLY RAVEN 405 EPOXY COATING, PER MANUFACTURER'S RECOMMENDATION, TO CHANNEL, SHELF, AND CONE SECTION. ENSURE INSIDE OF MANHOLE IS CLEAN AND DRY PRIOR TO COATING.
2. MARKER POSTS MAY BE REQUIRED IN EASEMENTS.
3. ALL PICK HOLES SHALL BE GROUTED ON THE INSIDE AND OUTSIDE OF MANHOLE.
4. MANHOLE LID SHALL BE ORIENTED PER THE DISTRICT'S DIRECTION.

**EXTRA SHALLOW SADDLE MANHOLE**

NOT TO SCALE

**DETAIL APPROVALS**  
**EDITOR** TMC  
**MANAGER** SJD

**NORTHSHORE UTILITY DISTRICT**  
**2024 STANDARD SEWER DETAILS**

**16**

LAST UPDATED  
 FEBRUARY 2020



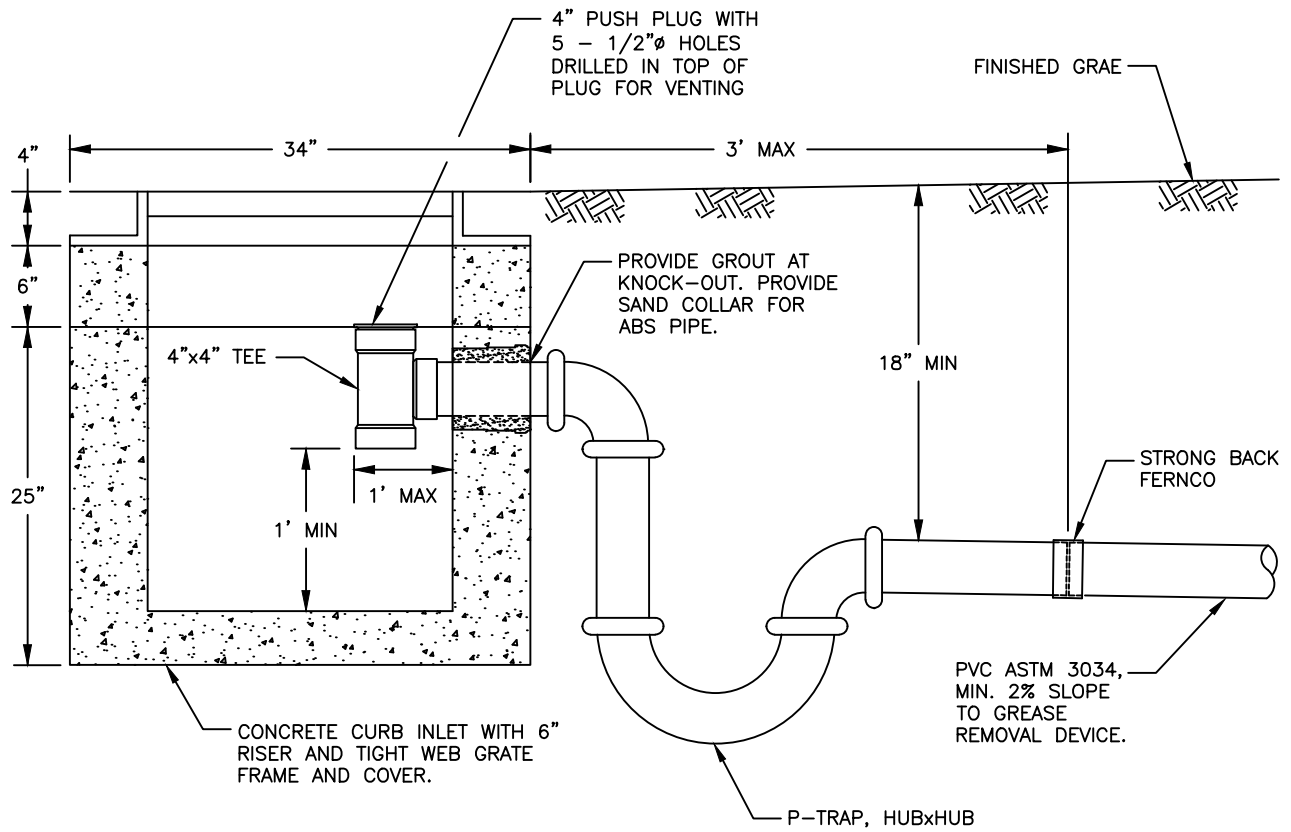

**SECTION A-A**

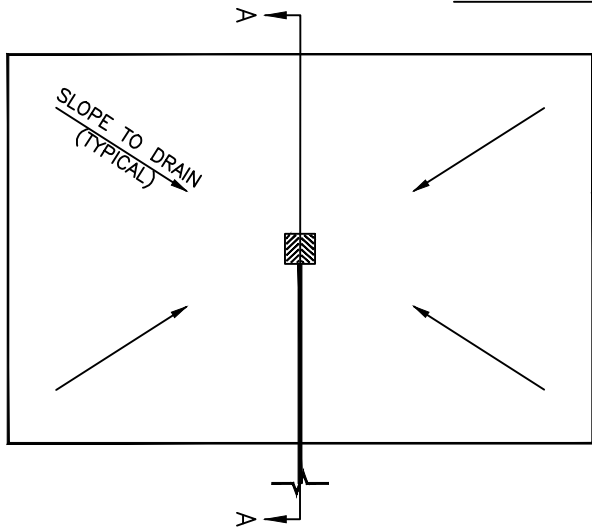

**PLAN**

UNCOVERED PAVED SERVICE AREA GRADED TO DRAIN SHALL NOT EXCEED 200 SQUARE FEET. AREAS OVER 200 SQUARE FEET REQUIRE ROOF CANOPY, WITH ROOF DRAINING TO STORM SYSTEM.

**NOTES:**

1. DUMPSTER DRAIN CONNECTION ONLY ALLOWED WHEN AUTHORIZED AND PERMITTED BY THE DISTRICT. CONTACT PERMITS@NUD.NET TO OBTAIN AUTHORIZATION AND FOR PERMITTING.
2. ALL PIPE SHALL BE ABS, SCHEDULE 40, SOLVENT WELD UNLESS OTHERWISE NOTED.
3. ALL FITTINGS SHALL BE ABS, HUBxHUB.
4. TRANSITION FROM ABS PIPE TO PVC PIPE SHALL BE MADE WITH A STRONG BACK FERNCO COUPLING ADAPTER.

**DUMPSTER DRAIN**

NOT TO SCALE

<b>DETAIL APPROVALS</b>	
<b>EDITOR</b>	TMC
<b>MANAGER</b>	EM

**NORTHSHORE UTILITY DISTRICT**  
2024 STANDARD SEWER DETAILS

**17**

LAST UPDATED  
MARCH 2024

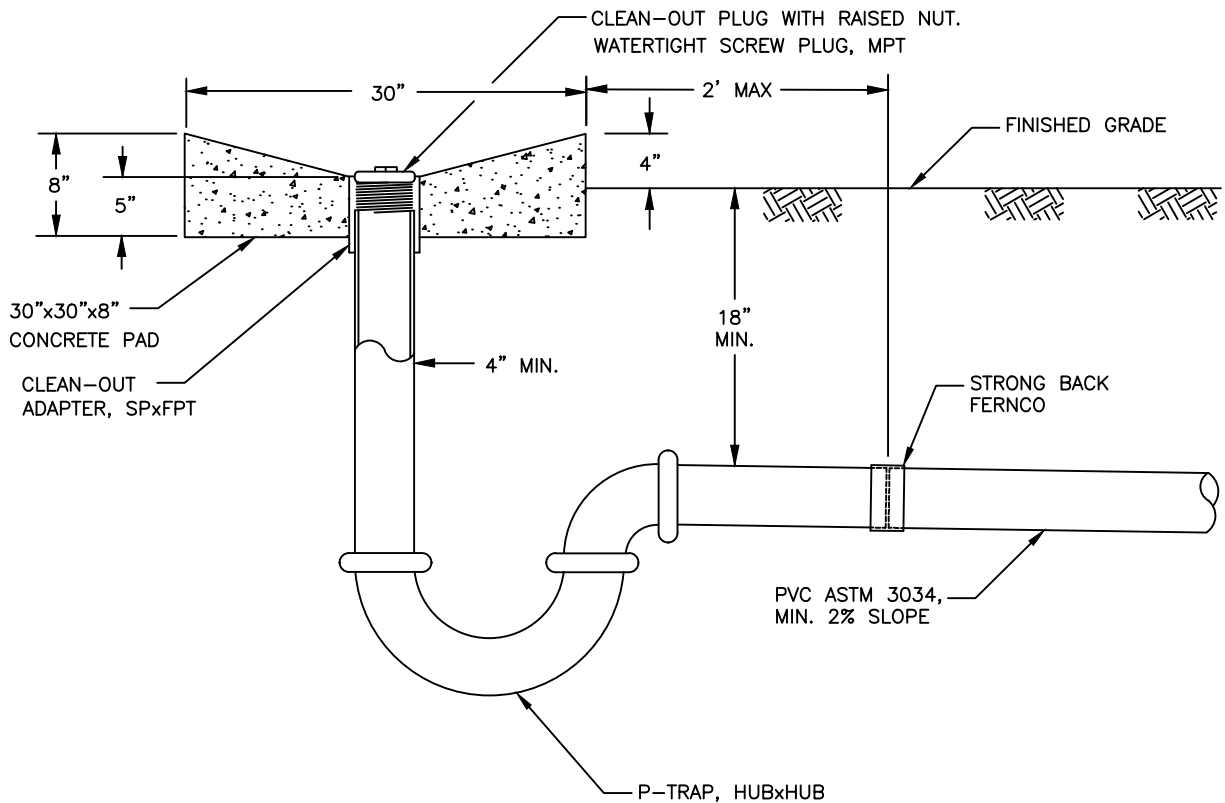

PROFILE

NOTES:

1. TRAILER DUMP CONNECTION ONLY ALLOWED WHEN AUTHORIZED AND PERMITTED BY THE DISTRICT. CONTACT PERMITS@NUD.NET TO OBTAIN AUTHORIZATION AND FOR PERMITTING.
2. ALL PIPE SHALL BE ABS, SCHEDULE 40, SOLVENT WELD UNLESS OTHERWISE NOTED.
2. ALL FITTINGS SHALL BE ABS, HUBxHUB.
3. TRANSITION FROM ABS PIPE TO PVC PIPE SHALL BE MADE WITH A STRONG BACK FERNCO COUPLING ADAPTER.

**TRAILER DUMP**

NOT TO SCALE

<b>DETAIL APPROVALS</b>	
<b>EDITOR</b>	<i>TMC</i>
<b>MANAGER</b>	<i>EM</i>

**NORTHSHORE UTILITY DISTRICT**  
**2024 STANDARD SEWER DETAILS**

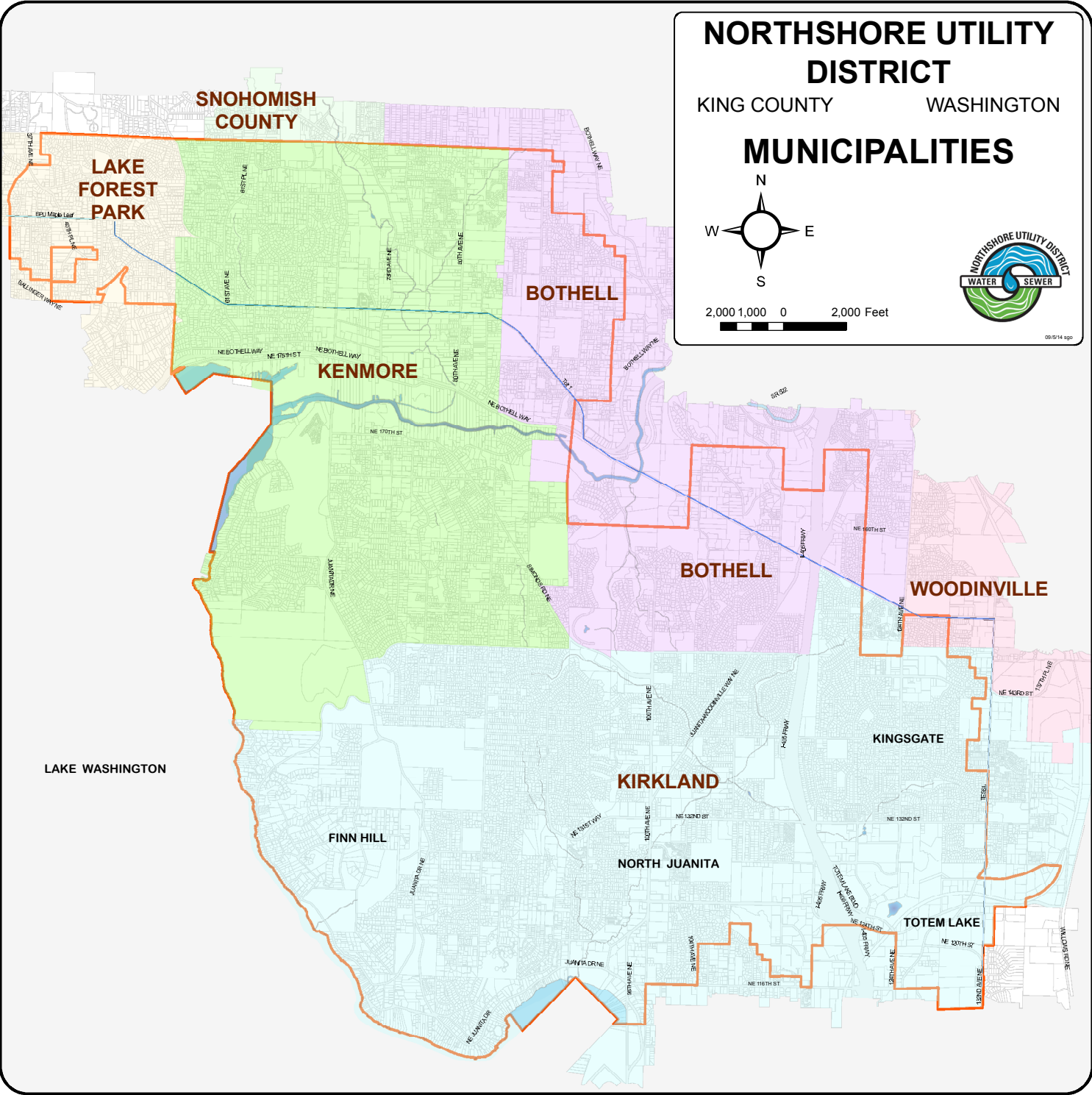

# NORTHSHORE UTILITY DISTRICT

KING COUNTY WASHINGTON

## MUNICIPALITIES

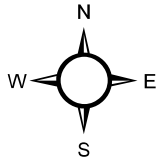

2,000 1,000 0 2,000 Feet



08/05/14 agp